

THIS DRAWING IS UNPUBLISHED. RELEASED FOR PUBLICATION
 © COPYRIGHT 20 ALL RIGHTS RESERVED.

LOC		DIST		REVISIONS			
P	LTR	DESCRIPTION	DATE	DWN	APVD		
AP	-						
E3		REVISED DESIGN ECO-11-009958	29JUN2011	NCL	MG		
F		REVISED DESIGN ECO-14-000611	14JAN2014	NCL	NMS		
G		REVISED BY ECO-17-005012	12APR2017	LAA	GOJ		
H		REVISED BY ECN-25-349674	20OCT2025	GCS	GCS		

creo
 Creo Parametric 2.0
DO NOT REVISE
EXCEPT BY CAD

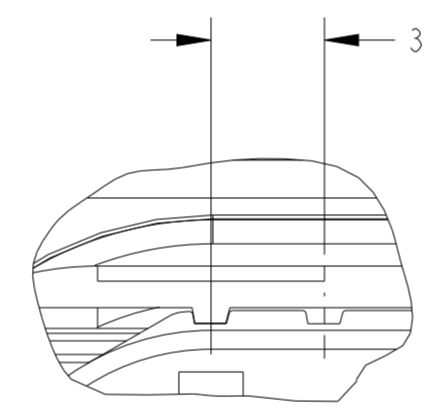
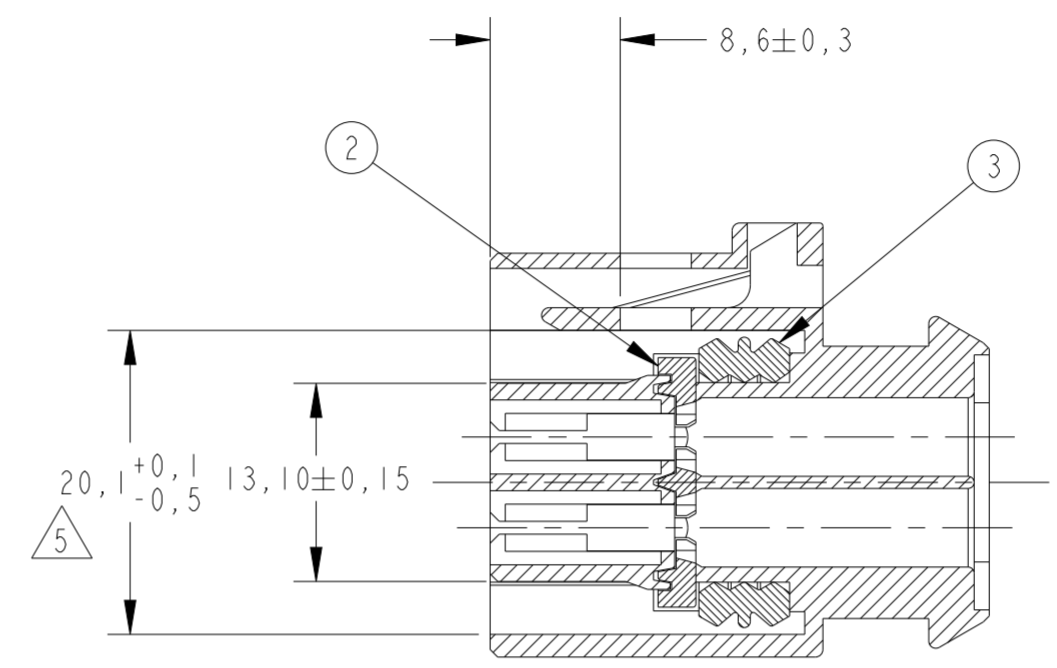
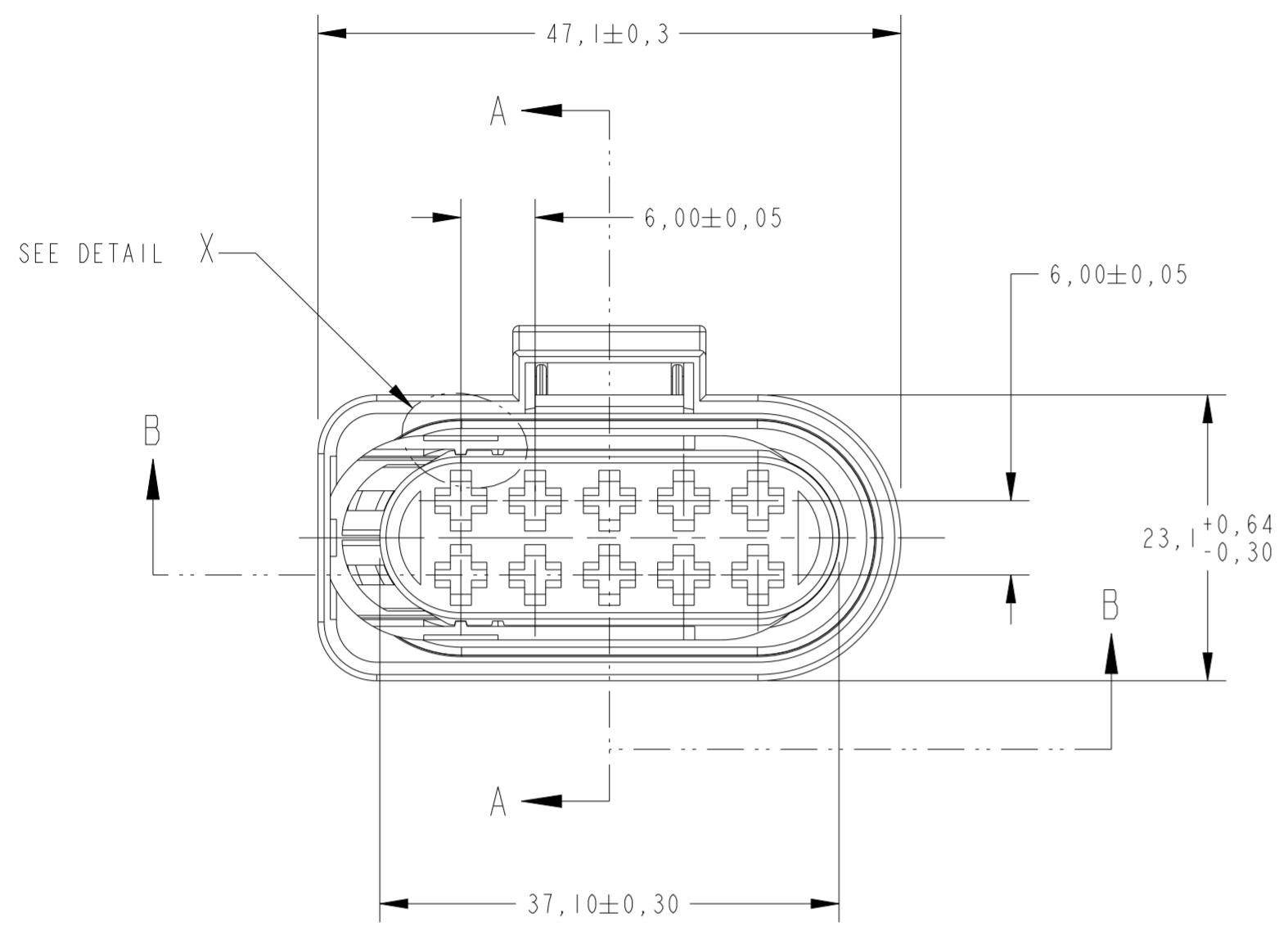

DETAIL X
 SCALE 5:1

AS PEÇAS SÃO FORNECIDAS
 COMO MOSTRADAS.
 THE PARTS MUST BE
 SUPPLIED AS SHOWN.

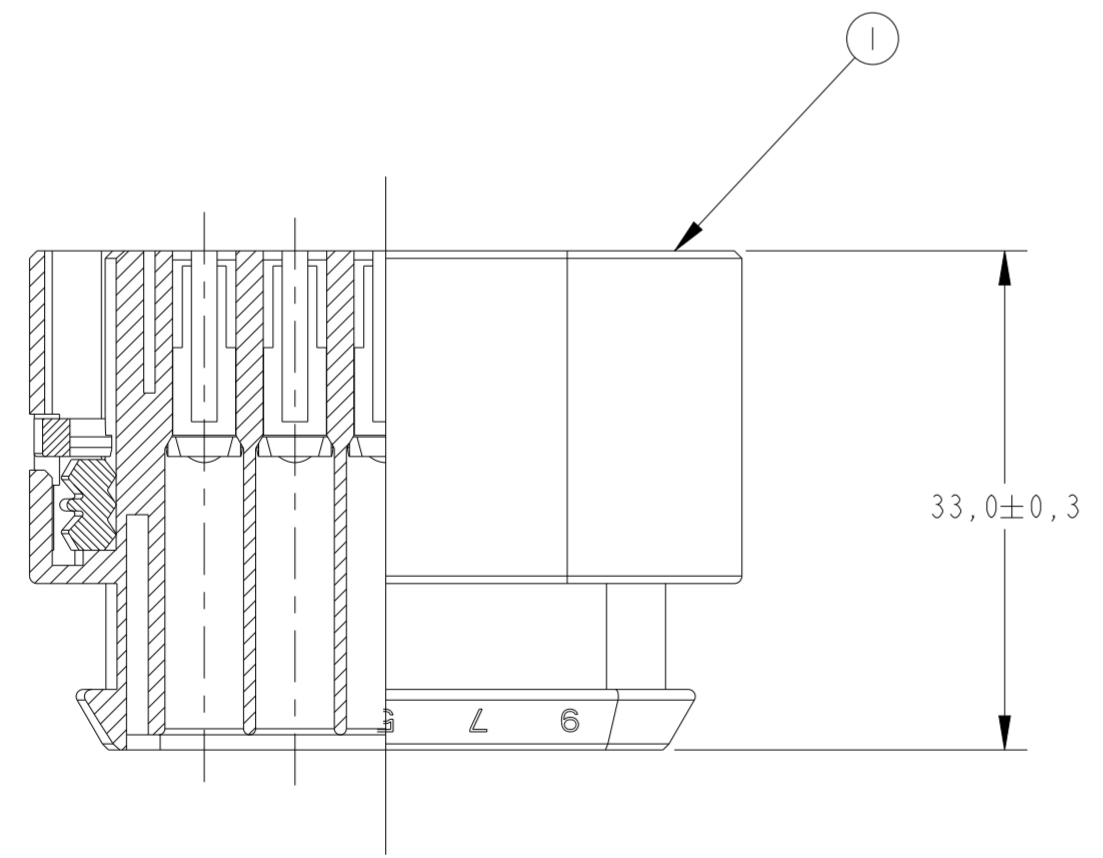

SECTION B-B

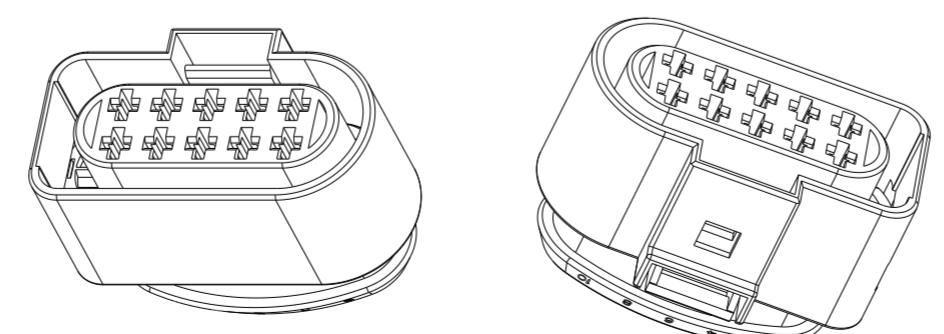

PERSPECTIVE VIEW
 SCALE 1:1

- ① - VER DESENHO DE CLIENTE RESTRITO 493577-1
- ② - USAR TERMINAIS CONFORME DESENHO DE CLIENTE 1355047.
- ③ - CONTRA PEÇA TE CONNECTIVITY UTILIZADA, VEJA DESENHO PN 493571.
- ④ - CONTRA PEÇA REFERÊNCIA VEJA FOLHA 2 DE 2.
- ⑤ - DIMENSÃO APENAS PARA TRAVA DO CONECTOR

- ① - SEE RESTRICTED CUSTOMER DRAWING 493577-1
- ② - USED WITH TERMINALS ACC. TO CUSTOMER DRAWING 1355047.
- ③ - FOR TE CONNECTIVITY MATING PART SEE PN DRAWING 493571.
- ④ - FOR REFERENCE MATING PART SEE SHEET 2 OF 2
- ⑤ - DIMENSION ONLY FOR CONNECTOR LOCKING.

GRAVAÇÃO MARKING
LOGOTIPO AMP AMP LOGO
CÓDIGO PAÍS PRODUTOR MANUFACTURER COUNTRY CODE
NOMENCLATURA MATERIAL MATERIAL NOMENCLATURE
NÚMERO COMPONENTE TE CONNECTIVITY TE CONNECTIVITY COMPONENT NUMBER
NÚMERO CAVIDADE CAVITY NUMBER
IDENTIFICAÇÃO CIRCUITO CIRCUIT IDENTIFICATION
PAÍS PRODUTOR MANUFACTURER COUNTRY
REV+ LETRA REV.DA PEÇA REV.+ PART REV.LETTER

REQ. PER ASS'Y	ITEM	DESCRIPTION	MATERIAL	FINISH
3	CONNECTOR SEAL		SILICONE	LARANJA/ORANGE
2	SLIDING LOCK, 10 POSN. J.P.TIMER RCPT.		PBT+10% FV /GF	VIOLETA/VIOLET
1	HSG., 10 POSN. J.P.TIMER, RCPT		PBT	PRETO/BLACK
493577				

THIS DRAWING IS A CONTROLLED DOCUMENT.

DIMENSIONS: mm

TOLERANCES UNLESS OTHERWISE SPECIFIED:

0 PLC	±
1 PLC	±0,2
2 PLC	±
3 PLC	±
4 PLC	±
ANGLES	±1°
FINISH	

MATERIAL: SEE TABLE

FINISH: SEE TABLE

APVD: N.C.LAPRESA 17JUN99

CHK: P.L.FARIA 17JUN99

APVD: P.R.SILVA 17JUN99

NAME: HSG., 10 POSN. J.P.TIMER, RCPT

SIZE: A2

CAGE CODE: 00779

DRAWING NO: C-493577

RESTRICTED TO: -

CUSTOMER DRAWING

SCALE: 2:1

SHEET: 1 OF 2

REV: H

THIS DRAWING IS UNPUBLISHED. RELEASED FOR PUBLICATION
 © COPYRIGHT 20 ALL RIGHTS RESERVED.

LOC		DIST		REVISIONS			
P	LTR	DESCRIPTION	DATE	DWN	APVD		
-	-	SEE SHEET 1	-	-	-	-	-

CONTRA PEÇA REFERÊNCIA
 REFERENCE MATING PART

SCALE 4:1

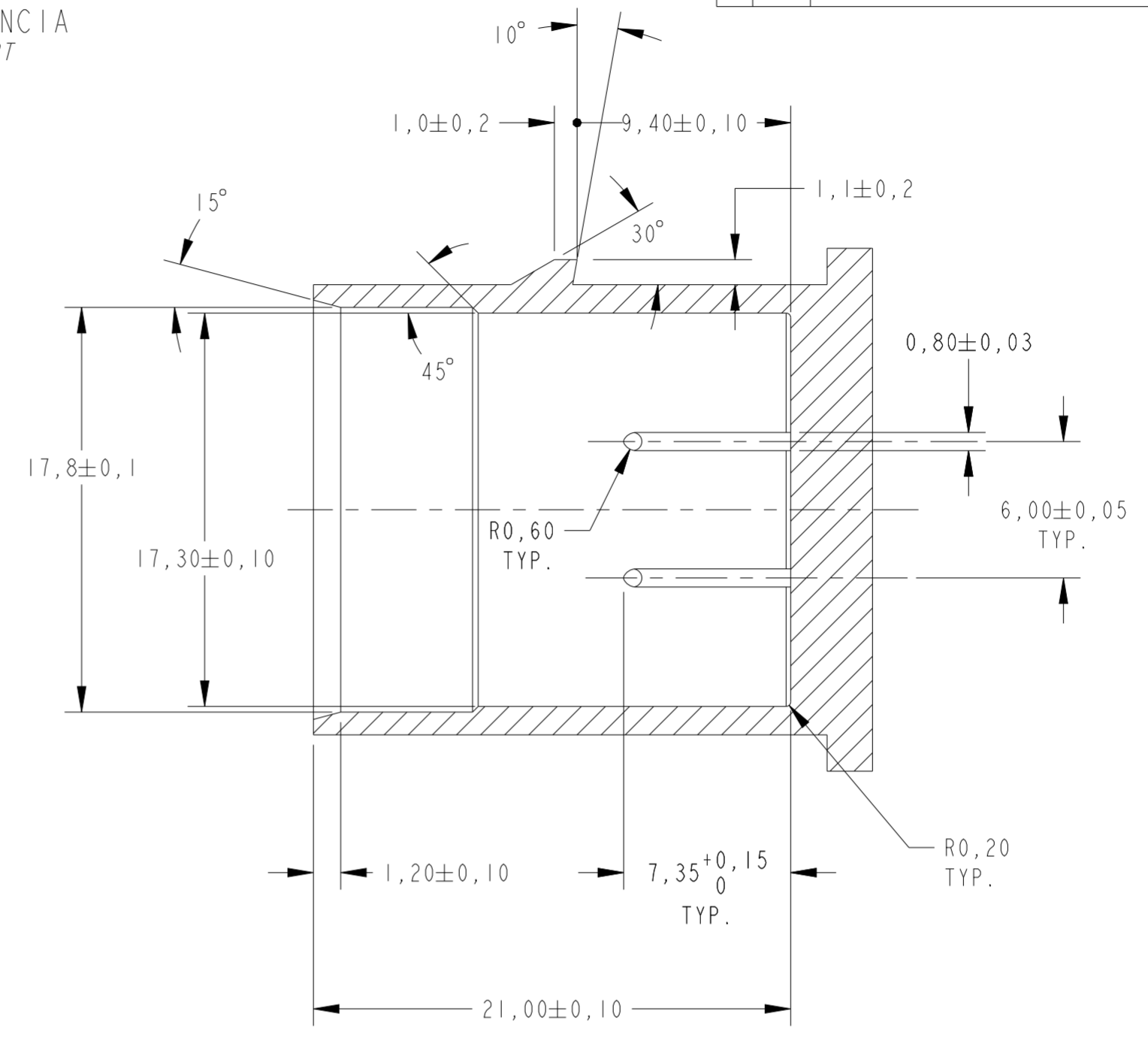
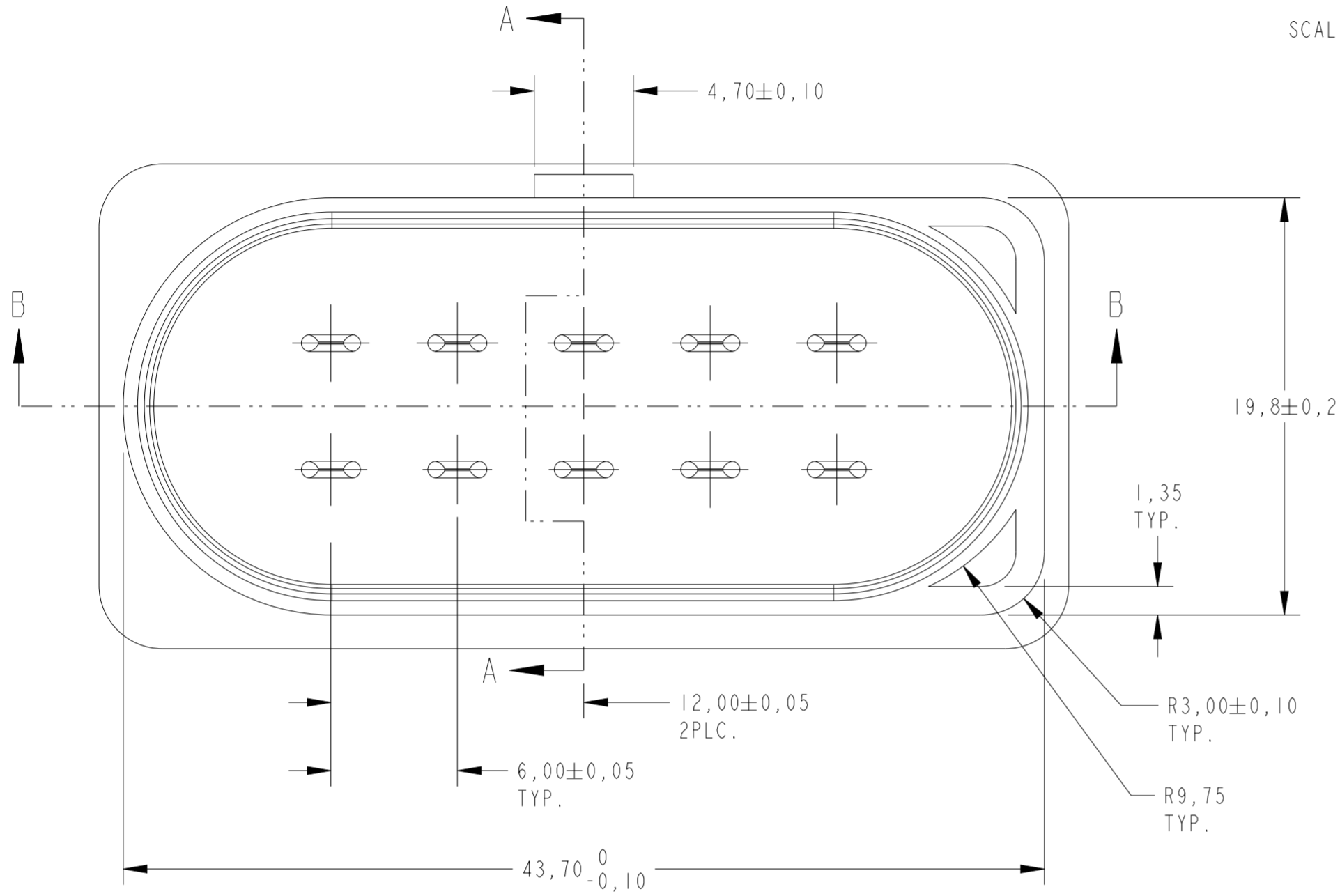

SECTION A-A

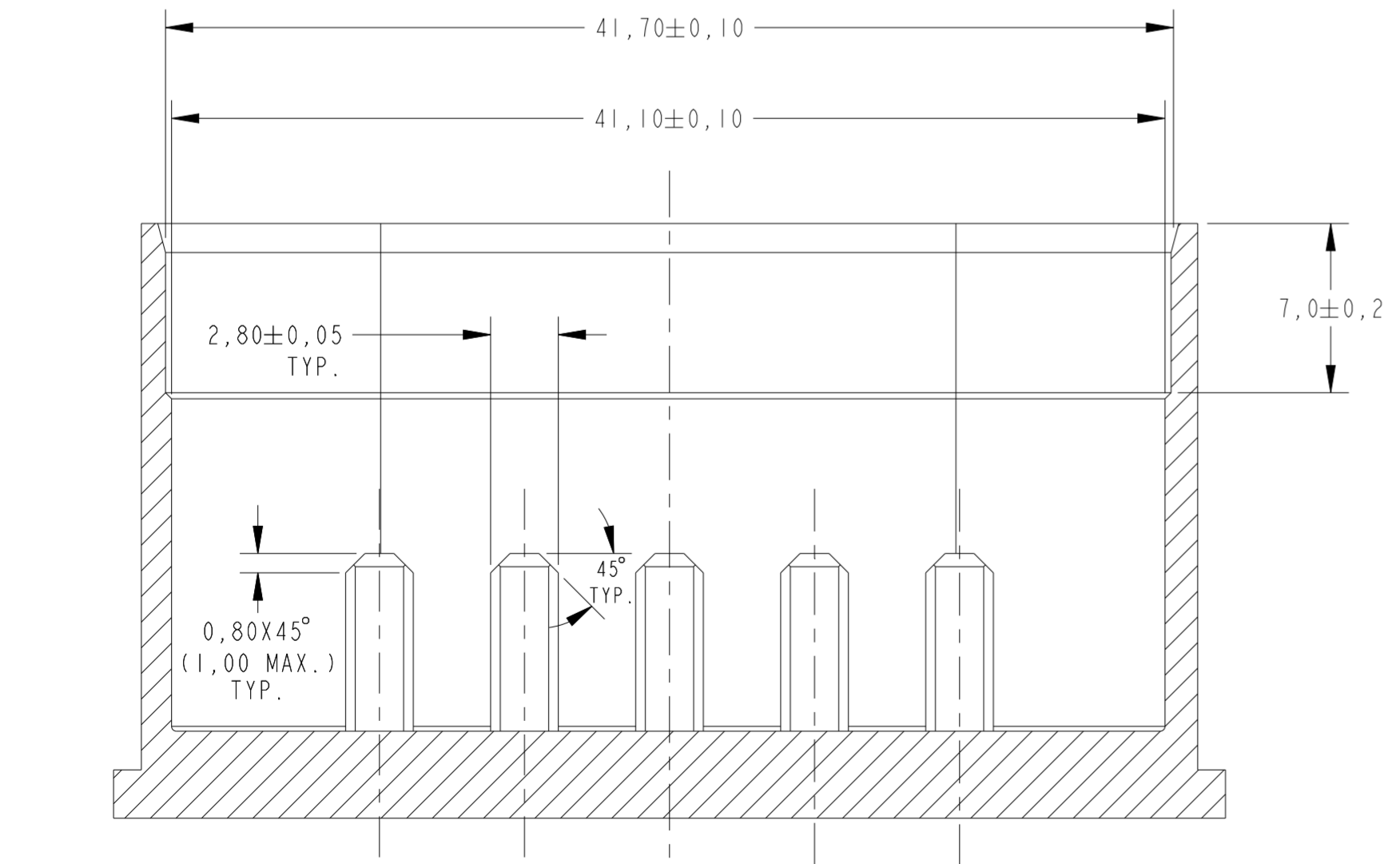

SECTION B-B

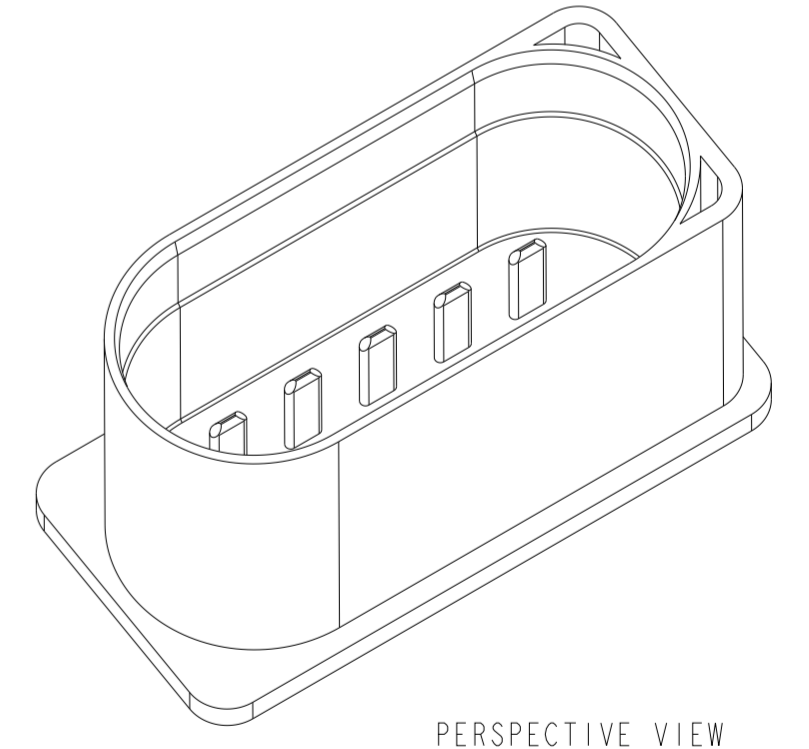

THIS DRAWING IS A CONTROLLED DOCUMENT.		DWN N.C.LAPRESA 17JUN99	TE Connectivity	
DIMENSIONS: mm		CHK P.L.FARIA 17JUN99		
TOLERANCES UNLESS OTHERWISE SPECIFIED:		APVD P.R.SILVA 17JUN99	NAME HSG., 10 POSN. J.P.TIMER, RCPT	
0 PLC ± 1 PLC ±0,2 2 PLC ± 3 PLC ± 4 PLC ± ANGLES ±1° FINISH		PRODUCT SPEC -	SIZE A2	
MATERIAL SEE TABLE		APPLICATION SPEC -	CAGE CODE 00779	DRAWING NO C-493577
SEE TABLE		WEIGHT -	RESTRICTED TO -	SCALE 2:1
		CUSTOMER DRAWING	SHEET 2	OF 2
			REV H	