



Contact Data

Size 8 Quadrax – ARINC 600, ARINC 404, MIL-C-81659, MIL-DTL-38999

Termination Type	Gender	Part Number	Type
Crimp***	Pin	224-0007-004	Rear Release/Rear Removable (RR-RR)
Crimp***	Socket	244-0011-000	Rear Release/Rear Removable (RR-RR)
Solder (PCB)	Pin	224-0007-000	Front Release/Front Removable* (FR-FR)
Solder (PCB)	Pin	224-0007-012	Front Release/Front Removable** (FR-FR)

* .250 solder extension

** .150 solder post extension

*** These contacts are designed to terminate 100 Ohm star Quad 24 AWG 100 Base-T Ethernet Cable with a max OD of .182. For other cable configurations consult factory.

Other PCB Solder configurations have been developed. Please contact Customer Service for further details.

Size 5 Quadrax – ARINC 404, MIL-C-81659 (33Q4M & 8Q8)

Termination Type	Gender	Part Number	Type
Crimp (Cable)	Pin	224-0007-005	Rear Release/Rear Removable
Crimp (Cable)	Socket	244-0011-001	Rear Release/Rear Removable

Crimping Tools

	Tool Handle	Die Set/Positioner
Center Contact	M22520/2-01	M22520/2-37 (Position 5)
Outer Body	M22520/5-01	M22520/5-45 (Position A)

Insertion / Removal Tools

Termination Type	Type	Contact Size	Insertion	Removal
Crimp (Cable)	RR-RR	8	None	Cannon Plastic Tool 323-7004-001
Crimp (Cable)	RR-RR	5	None	Cannon Plastic Tool 323-7011-000
Solder (PCB)	FR-FR	8	CIET 70369-8	CIET 70369-8

Filler Plug (for pin or socket crimp contacts)

Size 8, Aluminum Alloy with Nickel plating

For FR-FR Contacts Part Number 225-1065-001

For RR-RR Contacts

Part Number 225-1066-000

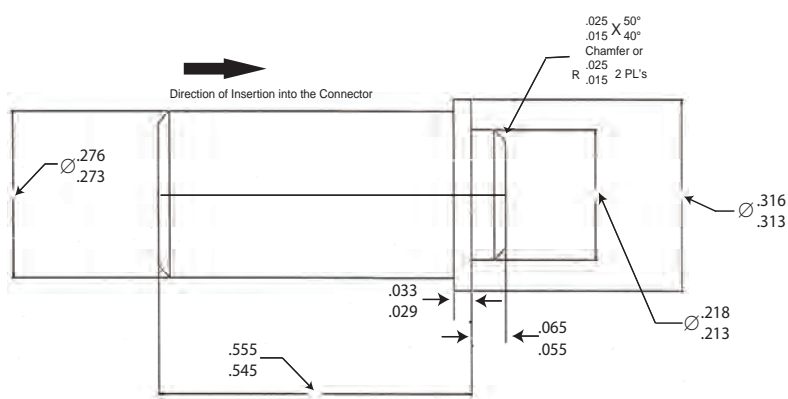
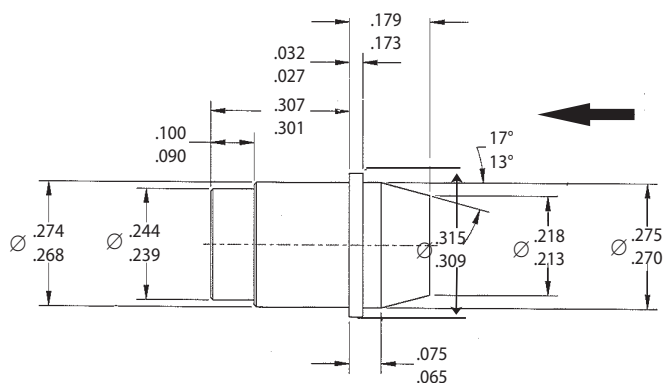

Dimensions shown in inches (mm)
Specifications and dimensions subject to change