



Product designation				Power contactor
Product type designation				BF18
<b>Contact characteristics</b>				
Number of poles	nr.			3
Rated insulation voltage $U_i$ IEC/EN	V			690
Rated impulse withstand voltage $U_{imp}$	kV			6
Operational frequency	min	Hz		25
	max	Hz		400
Conventional free air thermal current $I_{th}$ IEC/EN	A			32
Operational current $I_e$	AC-1 ( $\leq 40^\circ\text{C}$ )	A		32
	AC-3 ( $\leq 440\text{V} \leq 55^\circ\text{C}$ )	A		18
	AC-4 (400V)	A		8.5
Rated operational power AC-1 ( $T \leq 40^\circ\text{C}$ )	230V	kW		12
	400V	kW		21
	500V	kW		26
	690V	kW		36
Rated operational power AC-3 ( $T \leq 55^\circ\text{C}$ )	230V	kW		4
	400V	kW		7.5
	415V	kW		9
	440V	kW		9
	500V	kW		10
	690V	kW		10
Short-time allowable current for 10s (IEC/EN60947-1)	A			200
Protection fuse	gG (IEC)	A		32
	aM (IEC)	A		20
Making capacity (RMS value)	A			180
Breaking capacity at voltage	440V	A		144
	500V	A		120
	690V	A		94
Resistance per pole (average value)	$m\Omega$			2.5
Power dissipation per pole (average value)	$I_{th}$	W		2.6
	AC3	W		0.8
Tightening torque for terminals	min	Nm		1.5
	max	Nm		1.8
	min	lbin		1.1
	max	lbin		1.5
Tightening torque for coil terminal				

	min	Nm	0.8
	max	Nm	1
	min	lbft	0.8
	max	lbft	0.74
Max number of wires simultaneously connectable		nr.	2
Conductor section	AWG		
	/kcmil min		16
	/kcmil max		10
Flexible w/o lug conductor section	min	mm <sup>2</sup>	1
	max	mm <sup>2</sup>	6
Flexible c/w lug conductor section	min	mm <sup>2</sup>	1
	max	mm <sup>2</sup>	4
Flexible with insulated spade lug conductor section	min	mm <sup>2</sup>	1
	max	mm <sup>2</sup>	4
Power terminal protection according to IEC/EN 60529	IP20 when wired		
<b>Auxiliary contact characteristics</b>			
Type of contact	1 NO		
Thermal current I <sub>th</sub>	A	10	
IEC/EN 60947-5-1 designation	A600 - P600		
Operational current I <sub>e</sub> AC-1 (≤40°C)	A	32	
Operating current AC15	230V	A	3
	400V	A	1.9
	500V	A	1.4
Operating current DC12	110V	A	5.7
Operating current DC13	24V	A	5.7
	48V	A	2.9
	60V	A	2.3
	110V	A	Screw / DIN rail 35mm
	125V	A	0.6
	220V	A	0.2
	600V	A	1.2
<b>Ambient conditions</b>			
Temperature	Operating temperature		
	min	°C	-50
	max	°C	70
	Storage temperature		
	min	°C	-60
	max	°C	80
Max altitude		m	3000
Operational position	Operating position normal Operating position allowable		Vertical plan ±30°
Fixing	Screw / DIN rail 35mm		
Weight		g	0.35

**Operations**

Mechanical life	Cycles	20000000
Electrical life	Cycles	1600000

**Safety related data**

Performance level B10d according to EN/ISO 13489-1

	rated load mechanical load	Cicli Cicli	1600000 20000000
Mirror contats according to IEC/EN 609474-4-1			yes
EMC compatibility			yes

**AC coil operating**

AC operating voltage

of 50/60Hz coil powered at 50Hz			
pick-up			
	min	%Us	0.8
	max	%Us	1.1
drop-out			
	min	%Us	0.2
	max	%Us	0.55
of 50/60Hz coil powered at 60Hz			
pick-up			
	min	%Us	0.85
	max	%Us	1.1
drop-out			
	min	%Us	0.2
	max	%Us	0.55
of 60Hz coil powered at 60Hz			
pick-up			
	min	%Us	0.8
	max	%Us	1.1
drop-out			
	min	%Us	0.2
	max	%Us	0.55

AC operating voltage

of 50/60Hz coil powered at 50Hz			
	in-rush	VA	75
	holding	VA	9
of 50/60Hz coil powered at 60Hz			
	in-rush	VA	70
	holding	VA	6.5
of 60Hz coil powered at 60Hz			
	in-rush	VA	75
	holding	VA	9

Dissipation at holding ≤20°C 50Hz	W	2.5
-----------------------------------	---	-----

**Max cycles frequency**

Mechanical operations	Cycles/h	3600
-----------------------	----------	------

**Operating times**

Average time for Us control  
in AC

Closing NO			
	min	ms	8
	max	ms	24
Opening NO			
	min	ms	10
	max	ms	20

Closing NC	min	ms	14
	max	ms	28
Opening NC	min	ms	7
	max	ms	18

**UL technical data**

Full-load current (FLA) for three-phase AC motor

at 480V	A	14
at 600V	A	17

Yielded mechanical performance for

for single-phase AC motor

Yielded mechanical performance 110/120V	hp	1
Yielded mechanical performance 230V	hp	3

for three-phase AC motor

Yielded mechanical performance 200/208V	hp	5
Yielded mechanical performance 220/230V	hp	5
Yielded mechanical performance 460/480V	hp	10
Yielded mechanical performance 575/600V	hp	15

Contact rating of auxiliary contacts according to UL

A600 - P600

General USE

Contactor

AC current	A	32
------------	---	----

**Other features**

Pollution degree

3

**Dimensions**

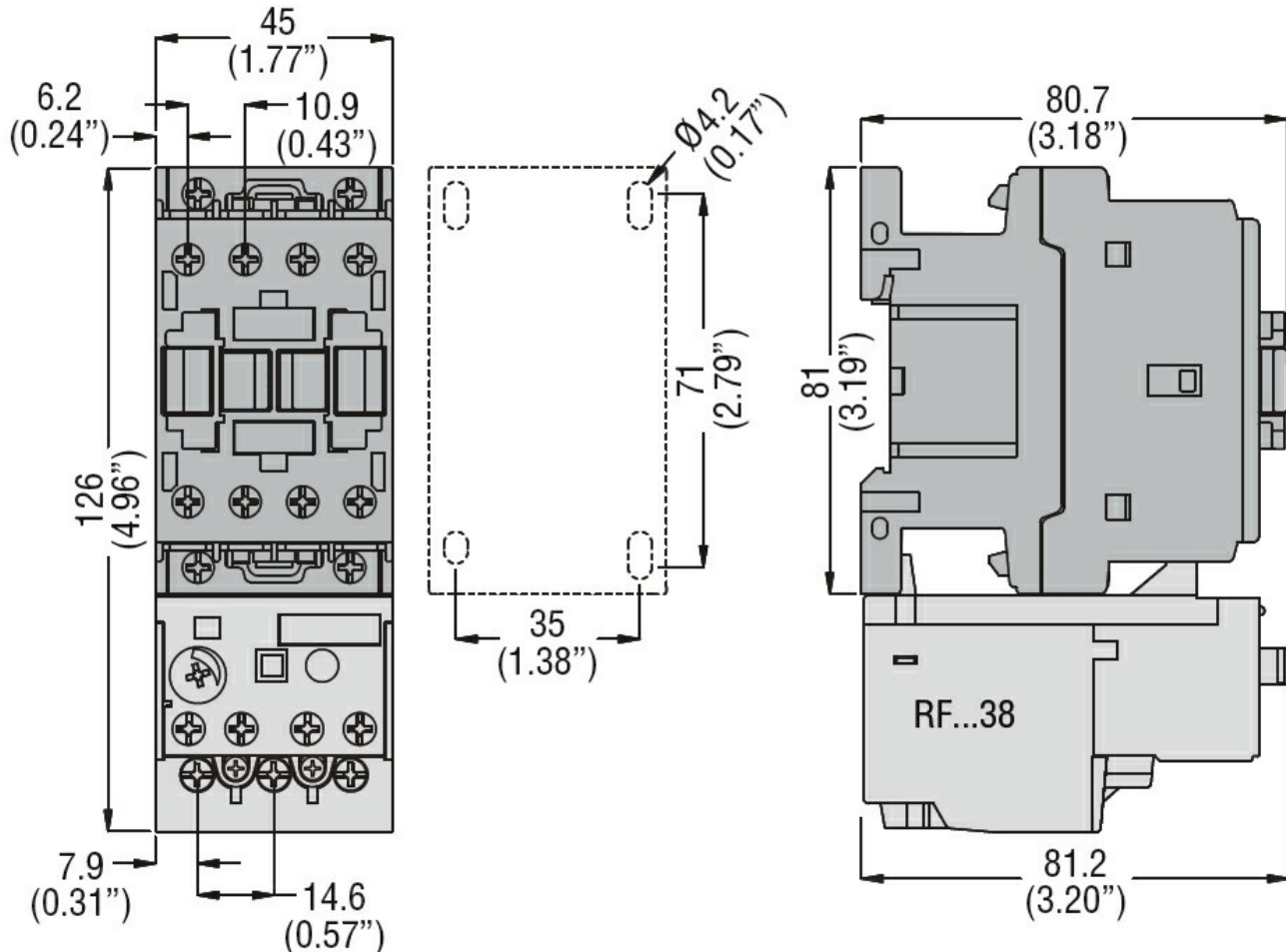

Wiring diagrams

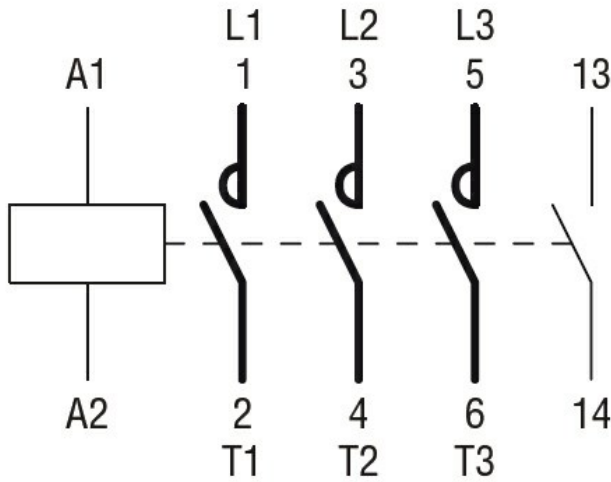

Certifications and compliance

Certifications

CSA C22.2 n° 60947-1

CSA C22.2 n° 60947-4-1

IEC/EN 60947-1

IEC/EN 60947-4-1

UL 60947-1

UL 60947-4-1

Compliance

CCC

cULus

EAC

ETIM 6 classification

EC000066 - Power contactor, AC switching