



*Representative photograph,
actual product appearance
may vary.*

*Due to regional agency
approval requirements,
some products may not be
available in your area.
Please contact your
regional Honeywell office
regarding your product of
choice.*

SDX15G2

Pressure Sensors: Measurement Type: Gage; 0 psig to 15 psig, Temperature Compensated Sensor, "G2" Package - Straight Port

Features

- Low Cost DIP
- Precision Temperature Compensation
- Calibrated Zero & Span
- Small Size
- Low Noise
- High Impedance for Low Power Applications
- Prime Grade Available (SDXxxxxy-A)

Typical Applications

- Medical Equipment
- Computer Peripherals
- Pneumatic Controls
- HVAC

Description

The SDX series sensors provide a very cost effective solution for pressure applications that require small size plus performance. These calibrated and temperature compensated sensors give an accurate and stable output over a 0 °C to 50 °C [32 °F to 122 °F] temperature range. This series is intended for use with non-corrosive, non-ionic working fluids such as air, dry gases and the like.

Devices are available to measure absolute and gage pressures from 1 psi (SDX01) up to 100 psi (SDX100). The absolute devices have an internal vacuum reference and an output voltage proportional to absolute pressure.

SDX Sensors are available in standard commercial and prime grades

(SDCxxxx - A) to allow optimization of accuracy and cost in any given application.

The SDX devices feature an integrated circuit (IC) sensor element and laser trimmed thick film ceramic housed in a compact solvent resistant case. The package is a double-wide (i.e. 0.600 inches lead spacing) dual-inline package (DIP). This is the same familiar package used by IC manufacturers except it is only 11,94 mm [0.470 in] long and has a pressure port(s). The pc board area used by each DIP is approximately 0.26 in x 0.26 in. This extremely small size enables the use of multiple sensors in limited available space. The DIP provides excellent corrosion resistance and isolation to external package stress.

The DIP mounts on a pc board like a standard IC with through-hole pins. The pins anchor the pressure sensor to the pc board and provide a more secure and stable unit than other types of packages. The output of the bridge is ratiometric to the supply voltage and operation from any Vdc supply voltage up to 20 Vdc is acceptable.



SDX15G2

Pressure Sensors: Measurement Type: Gage; 0 psig to 15 psig, Temperature Compensated Sensor, "G2" Package - Straight Port

Product Specifications	
Measurement Type	Gage
Signal Conditioning	Unamplified
Pressure Range	0 psig to 15 psig
Maximum Overpressure	30 psi
Supply Voltage	20 Vdc max.
Compensated	Yes
Output Calibration	Yes
Response Time	100 μ S
Termination	PCB
Port Style	Straight
Package Style	A2/G2 DIP

Full Scale Span	86.85 mV min, 90.00 mV typ., 93.15 mV max.
Null Shift over Temperature	± 0.2 % FS span typ., ± 1.0 % FS span max.; 0 °C to 50 °C [32 °F to 122 °F]
Span Shift Over Temperature	± 0.4 % FS span typ., ± 2.0 % FS span max.; 0 °C to 50 °C [32 °F to 122 °F]
Zero Pressure Offset	-1.0 mV min., 0.0 mV typ., 1.0 mV max.
Linearity, Hysteresis Error	± 0.2 typ. ± 1.0 max. %FS
Repeatability	± 0.2 % span typ., ± 0.5 % span max.
Input Resistance	4.0 kOhms typ.
Output Resistance	4.0 kOhms typ.
Operating Temperature Range	-40 °C to 85 °C [-40 °F to 185 °F]
Compensated Temperature Range	0 °C to 50 °C [32 °F to 122 °F]
Storage Temperature Range	-55 °C to 125 °C [-67 °F to 257 °F]
Media Compatibility	Clean, dry gases only
UNSPSC Code	411121
UNSPSC Commodity	411121 Transducers
Comment	Lead Temperature Soldering 2 s to 4 s at 250 °C [482 °F]
Availability	Global
Series Name	SDX Series

Honeywell

SDX15G2

Pressure Sensors: Measurement Type: Gage; 0 psig to 15 psig, Temperature Compensated Sensor, "G2" Package - Straight Port

For Reference Only mm [in]

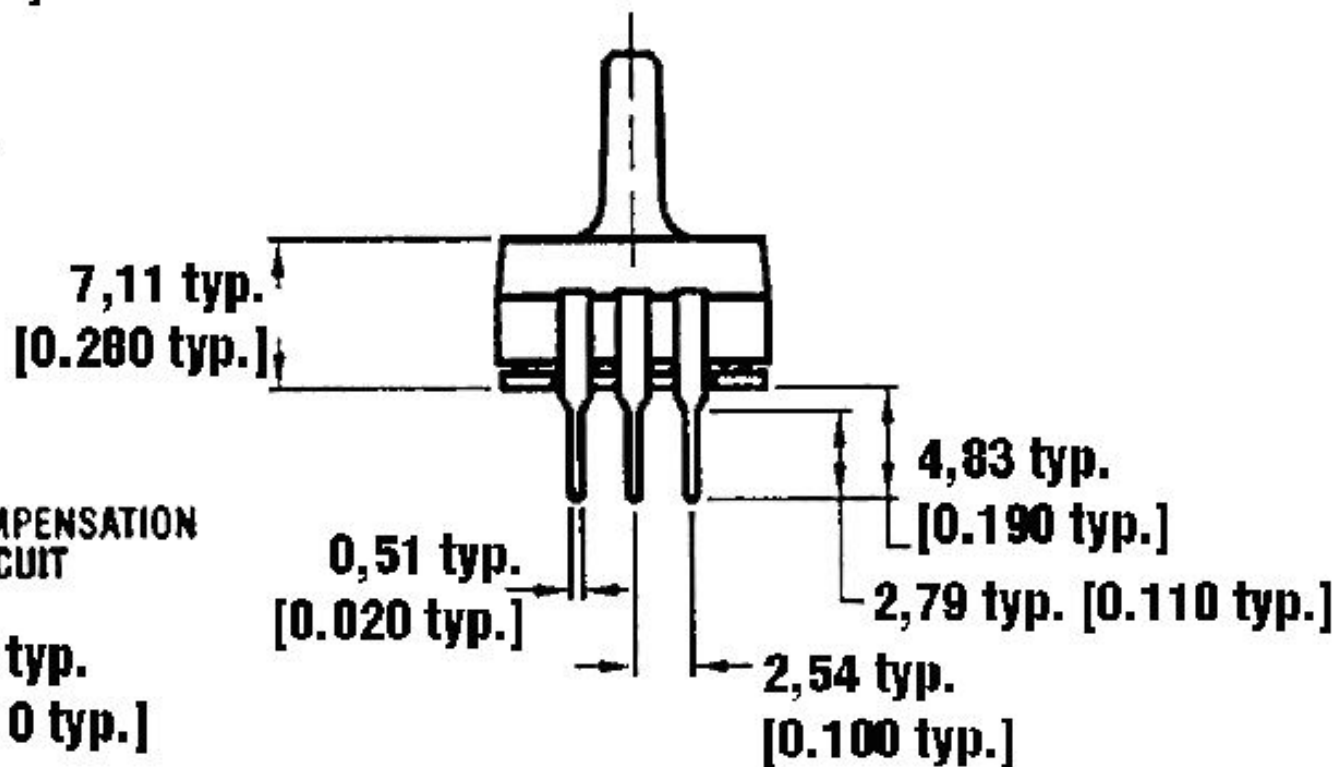
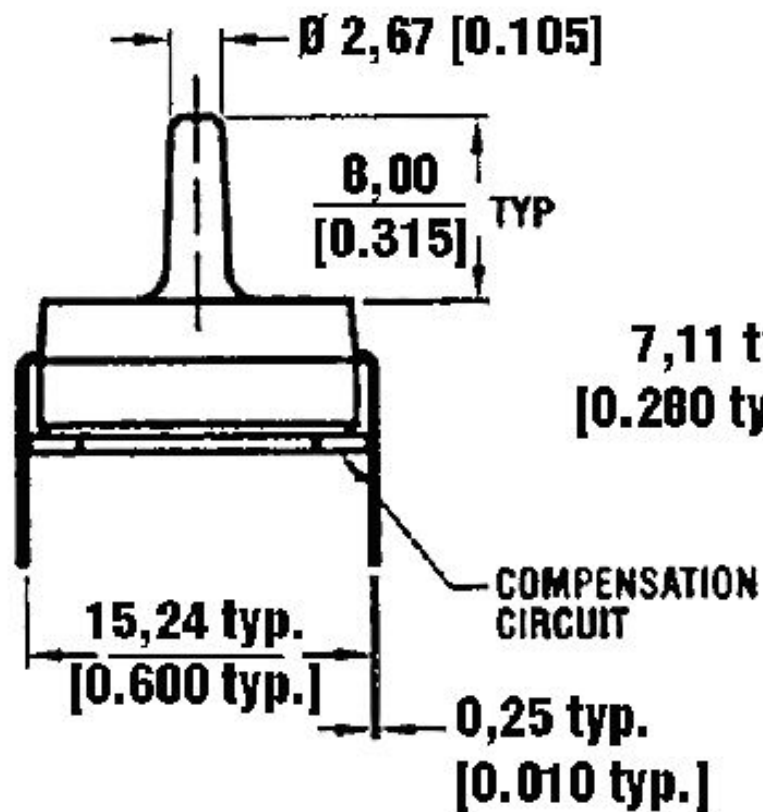
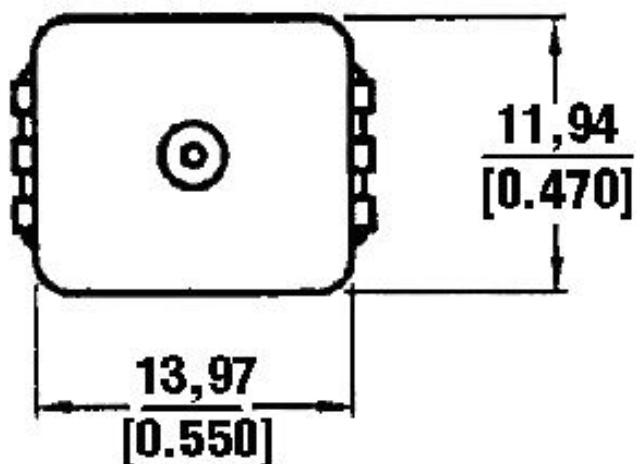

Honeywell

SDX15G2

Pressure Sensors: Measurement Type: Gage; 0 psig to 15 psig, Temperature Compensated Sensor, "G2" Package - Straight Port

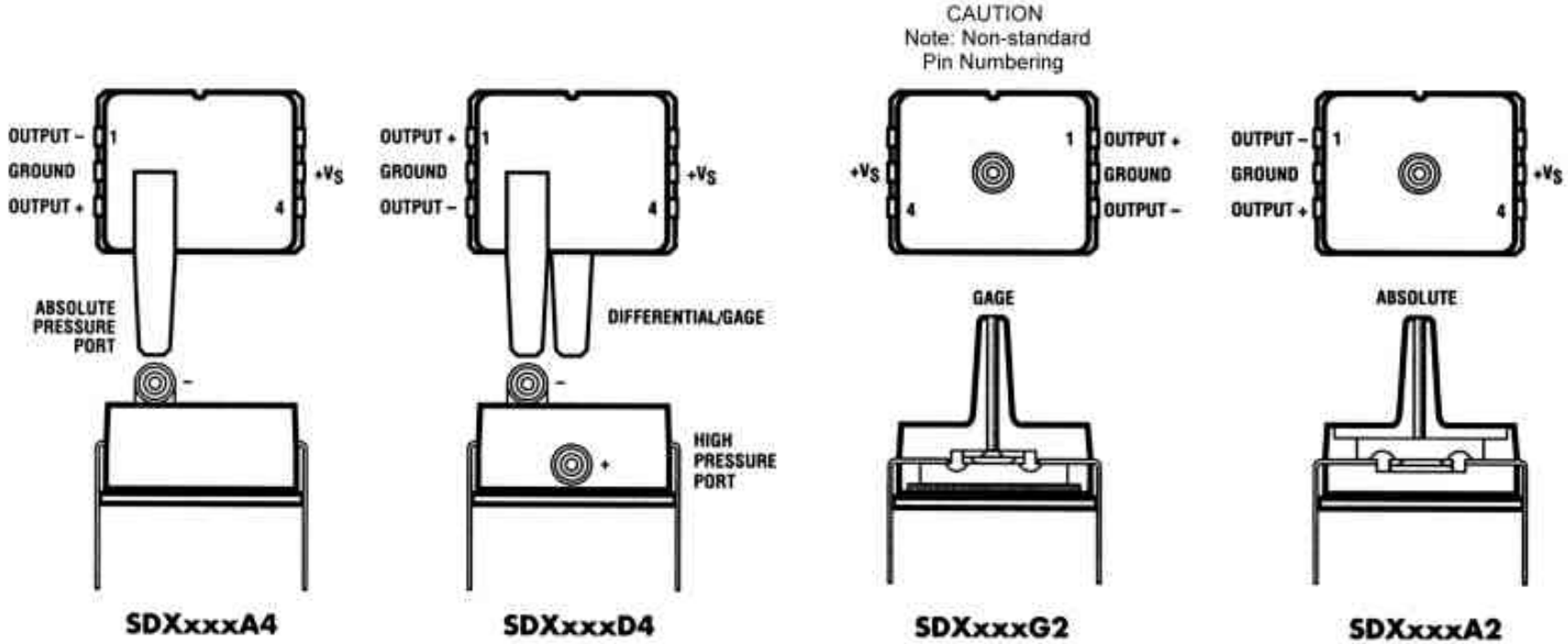

Honeywell

SDX15G2

Pressure Sensors: Measurement Type: Gage; 0 psig to 15 psig, Temperature Compensated Sensor, "G2" Package - Straight Port

 WARNING

PERSONAL INJURY

DO NOT USE these products as safety or emergency stop devices, or in any other application where failure of the product could result in personal injury.

Failure to comply with these instructions could result in death or serious injury.

 WARNING

MISUSE OF DOCUMENTATION

- The information presented in this product sheet (or catalog) is for reference only. DO NOT USE this document as product installation information.
- Complete installation, operation and maintenance information is provided in the instructions supplied with each product.

Failure to comply with these instructions could result in death or serious injury.

© Copyright Honeywell Inc.1998-2004 All rights reserved.