

Flat gasket - SACC-PG9-SEAL CLM - 1556320

Please be informed that the data shown in this PDF Document is generated from our Online Catalog. Please find the complete data in the user's documentation. Our General Terms of Use for Downloads are valid (<http://phoenixcontact.com/download>)

Pg9 flat gasket for the rear mounting of M12 flush-type connectors with Pg9 fastening threads



Key Commercial Data

Packing unit	1 pc
Minimum order quantity	10 pc
GTIN	 4 046356 176811
GTIN	4046356176811
Weight per Piece (excluding packing)	1.000 g
Custom tariff number	40169300
Country of origin	Germany

Technical data

Material

Sealing material	NBR
------------------	-----

Environmental Product Compliance

China RoHS	Environmentally friendly use period: unlimited = EFUP-e
	No hazardous substances above threshold values

Drawings

Flat gasket - SACC-PG9-SEAL CLM - 1556320

Dimensional drawing

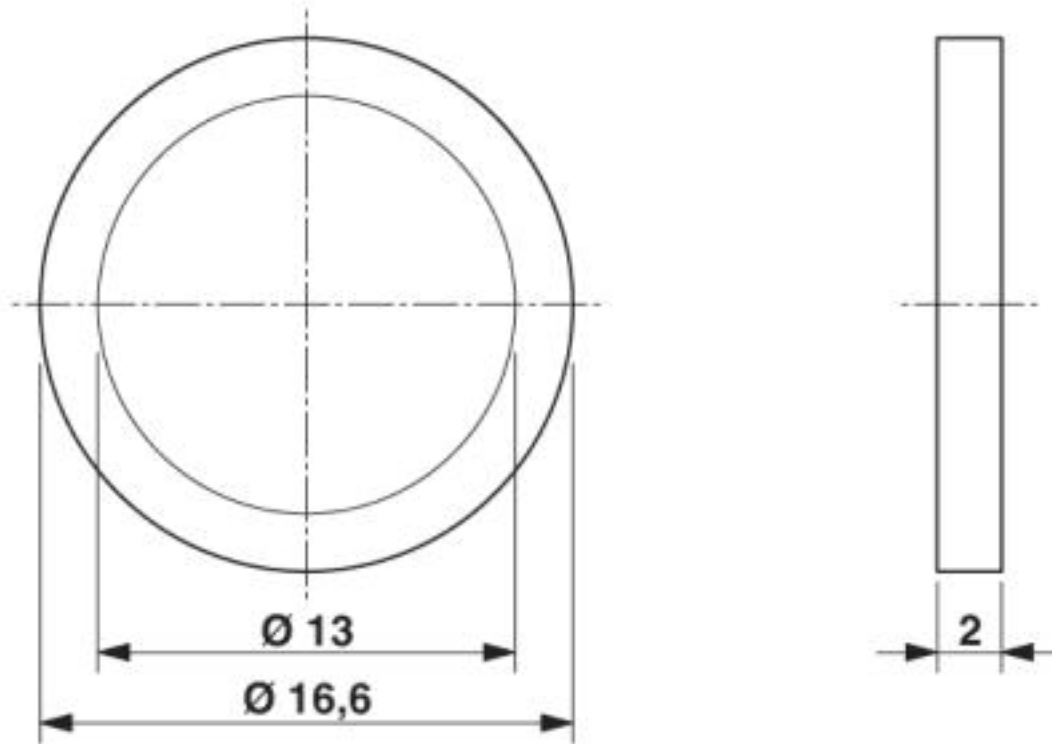

Classifications

eCl@ss

eCl@ss 10.0.1	27440102
eCl@ss 4.0	27140800
eCl@ss 4.1	27140800
eCl@ss 5.0	27143400
eCl@ss 5.1	27143400
eCl@ss 6.0	27279200
eCl@ss 7.0	27440103
eCl@ss 8.0	27440103
eCl@ss 9.0	27440102

ETIM

ETIM 3.0	EC001181
ETIM 4.0	EC001181
ETIM 5.0	EC002061
ETIM 6.0	EC002061

Flat gasket - SACC-PG9-SEAL CLM - 1556320

Classifications

UNSPSC

UNSPSC 6.01	31251501
UNSPSC 7.0901	31251501
UNSPSC 11	31251501
UNSPSC 12.01	31251501
UNSPSC 13.2	39121413
UNSPSC 18.0	39121413
UNSPSC 19.0	39121413
UNSPSC 20.0	39121413
UNSPSC 21.0	39121413

Approvals

Approvals

Approvals

EAC

Ex Approvals

Approval details

EAC		B.01742
-----	---	---------
