

## Electronic housing - UEGM 25-FS/FS - 2792086

Please be informed that the data shown in this PDF Document is generated from our Online Catalog. Please find the complete data in the user's documentation. Our General Terms of Use for Downloads are valid (<http://phoenixcontact.com/download>)



Electronic housing, for PCB insertion, fully equipped with 3 screw or 6 tab connections per side

The figure shows version UEGM 22,5-FS/FS

### Your advantages

- ✓ Cost-effective series production, since the base element and the assembled PCB are soldered by machine
- ✓ Can be snapped onto standard NS 35/7,5 and NS 35/15 DIN rails
- ✓ Efficient assembly thanks to overlapping housing parts
- ✓ Complex electronic circuits can be integrated, with up to 24 connections on two levels

### Key Commercial Data

|                                      |   |
|--------------------------------------|---|
| Packing unit                         | 1 pc  |
| Minimum order quantity               | 10 pc   |
| GTIN                                 | <br>4 017918 072551 |
| GTIN                                 | 4017918072551   |
| Weight per Piece (excluding packing) | 63.210 g  |
| Custom tariff number                 | 85369010  |
| Country of origin                    | Germany   |

### Technical data

#### General

|                  |                    |
|------------------|--------------------|
| Housing type     | Complete housing   |
| Housing material | Polyamide (PA 6.6) |
| Color (RAL)      | green              |

## Electronic housing - UEGM 25-FS/FS - 2792086

### Technical data

#### Ambient conditions

|                                 |                   |
|---------------------------------|-------------------|
| Ambient temperature (operation) | -40 °C ... 105 °C |
|---------------------------------|-------------------|

#### Dimensions

|        |         |
|--------|---------|
| Length | 101 mm  |
| Height | 85.5 mm |
| Width  | 25 mm   |
| Depth  | 101 mm  |

#### Technical data

|                                  |      |
|----------------------------------|------|
| Power dissipation without gap    | 4 W  |
| Power dissipation with 20 mm gap | 10 W |
| Number of positions              | 12   |

#### Connection data

|                                       |                     |
|---------------------------------------|---------------------|
| Conductor cross section solid min.    | 0.2 mm <sup>2</sup> |
| Conductor cross section solid max.    | 4 mm <sup>2</sup>   |
| Conductor cross section flexible min. | 0.2 mm <sup>2</sup> |
| Conductor cross section flexible max. | 2.5 mm <sup>2</sup> |
| Conductor cross section AWG min.      | 24                  |
| Conductor cross section AWG max.      | 12                  |

#### Standards and Regulations

|  |    |
|--|----|
| Flammability rating according to UL 94 | V2 |
|--|----|

#### Environmental Product Compliance

|            |   |
|------------|---|
| China RoHS | Environmentally friendly use period: unlimited = EFUP-e |
|            | No hazardous substances above threshold values          |

### Drawings

# Electronic housing - UEGM 25-FS/FS - 2792086

Dimensional drawing

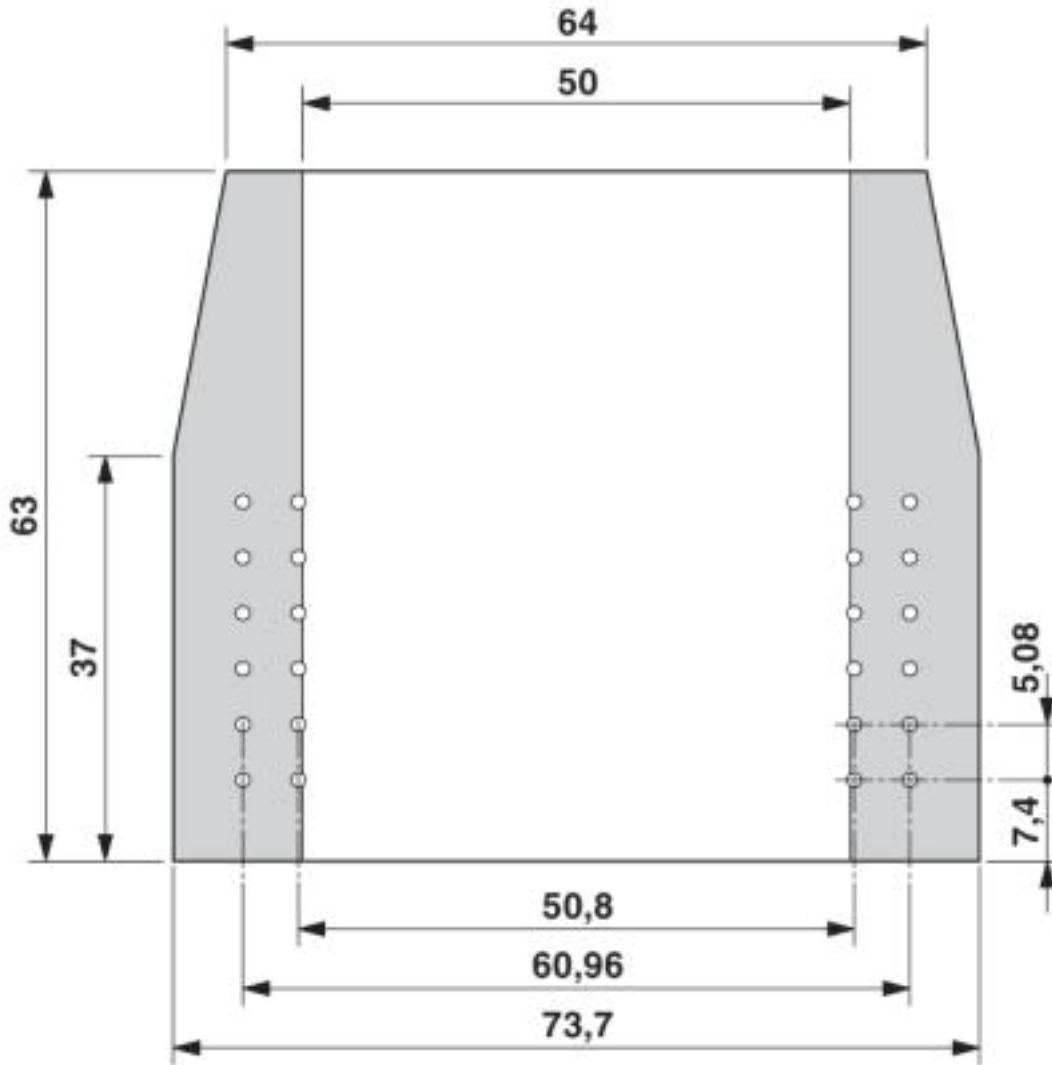

## Electronic housing - UEGM 25-FS/FS - 2792086

Exploded view

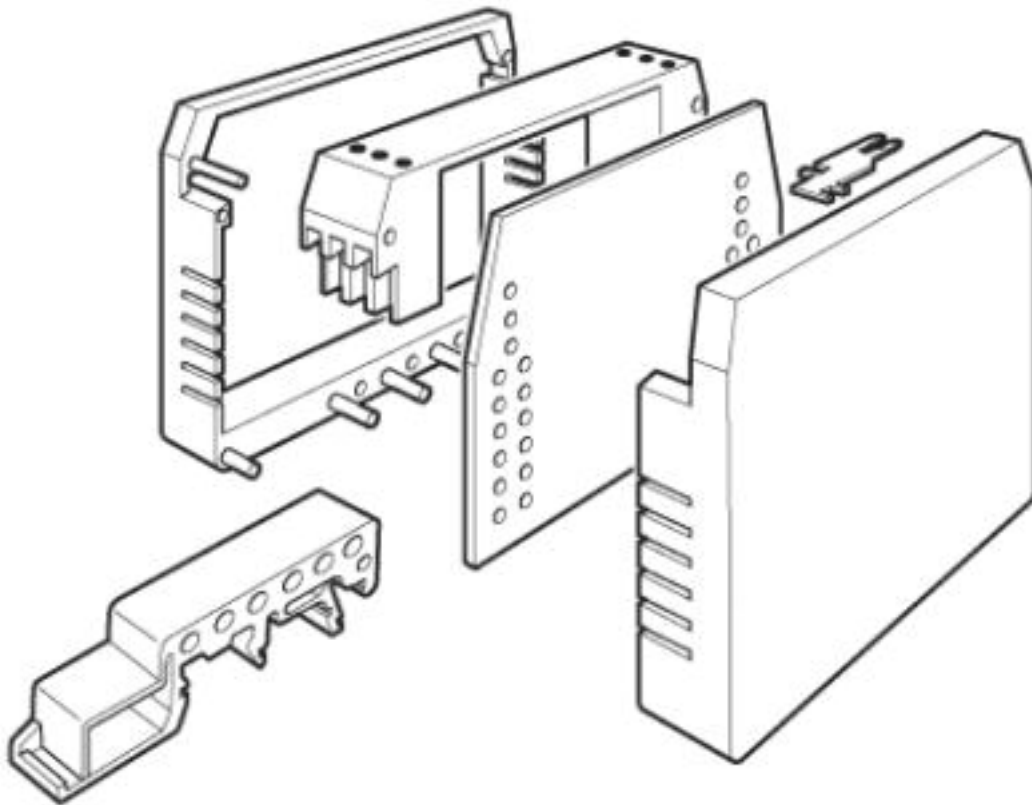

# Electronic housing - UEGM 25-FS/FS - 2792086

Dimensional drawing

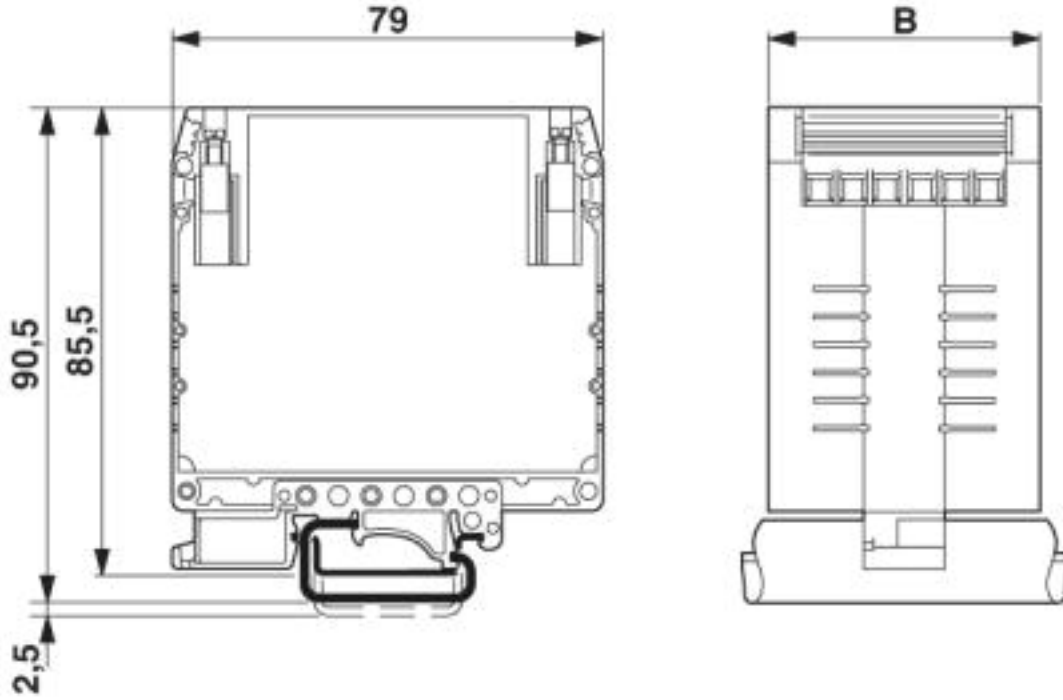

## Electronic housing - UEGM 25-FS/FS - 2792086

Schematic diagram

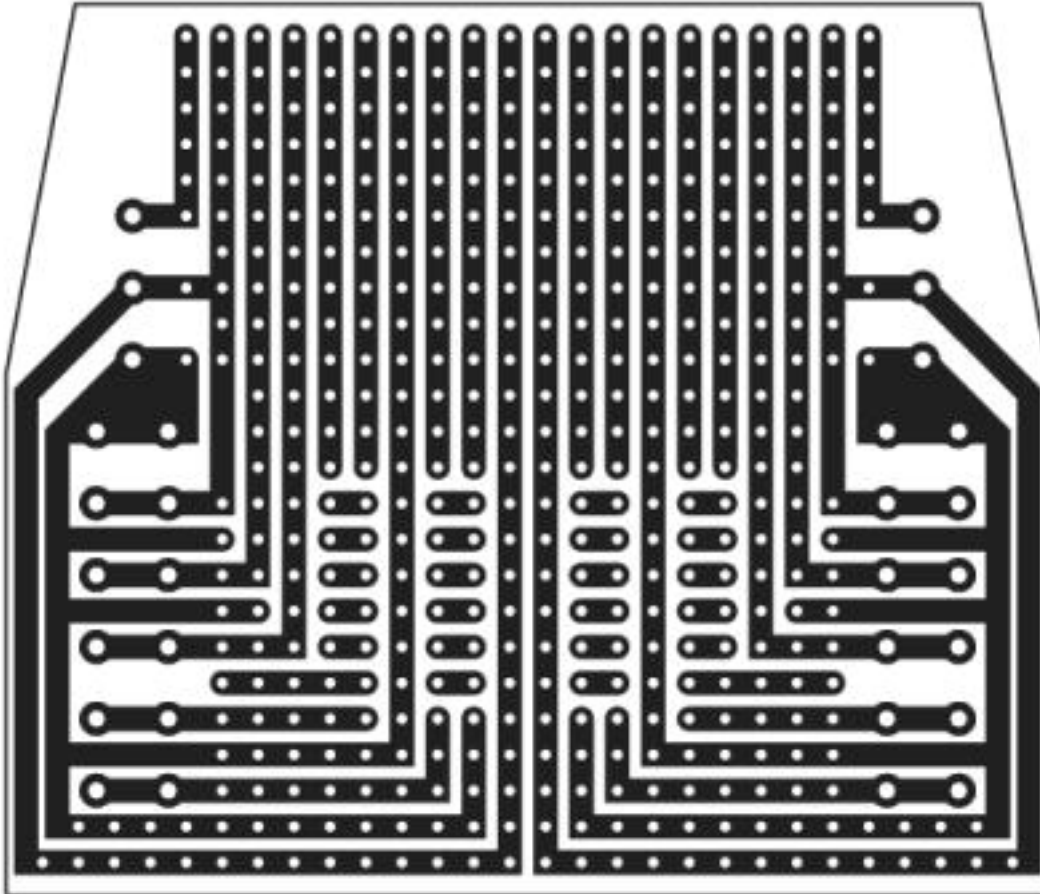

### Classifications

eCl@ss

|               |          |
|---------------|----------|
| eCl@ss 10.0.1 | 27182702 |
| eCl@ss 4.0    | 27180400 |
| eCl@ss 4.1    | 27180400 |
| eCl@ss 5.0    | 27180500 |
| eCl@ss 5.1    | 27180500 |
| eCl@ss 6.0    | 27180800 |
| eCl@ss 7.0    | 27182702 |
| eCl@ss 8.0    | 27182702 |
| eCl@ss 9.0    | 27182702 |

# Electronic housing - UEGM 25-FS/FS - 2792086

## Classifications

### ETIM

|          |          |
|----------|----------|
| ETIM 2.0 | EC001031 |
| ETIM 3.0 | EC001031 |
| ETIM 4.0 | EC001031 |
| ETIM 5.0 | EC001031 |
| ETIM 6.0 | EC001031 |
| ETIM 7.0 | EC001031 |

### UNSPSC

|               |          |
|---------------|----------|
| UNSPSC 6.01   | 31261501 |
| UNSPSC 7.0901 | 31261501 |
| UNSPSC 11     | 31261501 |
| UNSPSC 12.01  | 31261501 |
| UNSPSC 13.2   | 31261501 |
| UNSPSC 18.0   | 31261501 |
| UNSPSC 19.0   | 31261501 |
| UNSPSC 20.0   | 31261501 |
| UNSPSC 21.0   | 31261501 |

## Approvals

### Approvals

Approvals

UL Recognized / EAC

Ex Approvals

### Approval details

|               |  |   |               |
|---------------|--|---|---------------|
| UL Recognized |  | <a href="http://database.ul.com/cgi-bin/XYV/template/LISEXT/1FRAME/index.htm">http://database.ul.com/cgi-bin/XYV/template/LISEXT/1FRAME/index.htm</a> | FILE E 240868 |
|---------------|--|---|---------------|

|     |  |  |         |
|-----|--|--|---------|
| EAC |  |  | B.01742 |
|-----|--|--|---------|

## Electronic housing - UEGM 25-FS/FS - 2792086

### Accessories

#### Accessories

#### PCB

#### PCB - P 1-UEGM - 2792109

PCB, for screw and slip-on connection, for custom fitting electronic components.

