

Electronic housing - UEGM 40/1 - 2792112

Please be informed that the data shown in this PDF Document is generated from our Online Catalog. Please find the complete data in the user's documentation. Our General Terms of Use for Downloads are valid (<http://phoenixcontact.com/download>)



Electronic housing, for PCB insertion, fully equipped with 3 screw or 6 tab connections per side

Product Features

- Cost-effective series production, since the base element and the assembled PCB are soldered by machine
- Complex electronic circuits can be integrated, with up to 24 connections on two levels
- Efficient assembly thanks to overlapping housing parts
- Can be snapped onto standard NS 35/7,5 and NS 35/15 DIN rails



Key Commercial Data

Packing unit	1 pc
GTIN	 4 017918 072582
Weight per Piece (excluding packing)	74.1 g
Custom tariff number	85369010
Country of origin	Germany

Technical data

General

Housing type	Complete housing
Housing material	Polyamide (PA 6.6)
Color	green

Ambient conditions

Ambient temperature (operation)	-40 °C ... 105 °C
---------------------------------	-------------------

Dimensions

Length	79 mm
--------	-------

Electronic housing - UEGM 40/1 - 2792112

Technical data

Dimensions

Constructional height	85.5 mm
Width	40 mm
Pitch	5 mm

Technical data

Connection in acc. with standard	CUL
Nominal voltage U_N	300 V
Nominal current I_N	10 A
AWG/kcmil	30-12
Indicator1	CUL1
Flammability rating according to UL 94	V0
Power dissipation without gap	5.2 W
Power dissipation with 20 mm gap	11.2 W
Number of positions	6

Connection data

Conductor cross section solid min.	0.2 mm ²
Conductor cross section solid max.	4 mm ²
Conductor cross section flexible min.	0.2 mm ²
Conductor cross section flexible max.	2.5 mm ²
Conductor cross section AWG min.	24
Conductor cross section AWG max.	12
Stripping length	8 mm

Standards and Regulations

Connection in acc. with standard	CUL
Flammability rating according to UL 94	V0

Classifications

eCl@ss

eCl@ss 4.0	27180401
eCl@ss 4.1	27180401
eCl@ss 5.0	27180506
eCl@ss 5.1	27180506
eCl@ss 6.0	27180802
eCl@ss 7.0	27182702
eCl@ss 8.0	27182702
eCl@ss 9.0	27182702

Electronic housing - UEGM 40/1 - 2792112

Classifications

ETIM

ETIM 2.0	EC001031
ETIM 3.0	EC001031
ETIM 4.0	EC001031
ETIM 5.0	EC001031

UNSPSC

UNSPSC 6.01	31261501
UNSPSC 7.0901	31261501
UNSPSC 11	31261501
UNSPSC 12.01	31261501
UNSPSC 13.2	31261501

Approvals

Approvals

Approvals

UL Recognized / cUL Recognized / EAC / UL Recognized / cULus Recognized

Ex Approvals

Approvals submitted

Approval details

UL Recognized

cUL Recognized	
mm ² /AWG/kcmil	30-12
Nominal current I _N	10 A

Electronic housing - UEGM 40/1 - 2792112

Approvals

Nominal voltage UN	300 V
--------------------	-------

EAC

UL Recognized	
mm ² /AWG/kcmil	30-12
Nominal current IN	10 A
Nominal voltage UN	300 V

cULus Recognized

Drawings

Dimensional drawing

Soldering side of PCB layout 1 = Overall component area

Explosion drawing

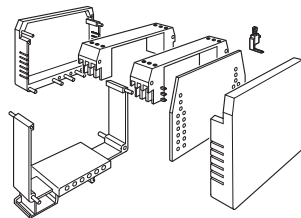

Dimensional drawing

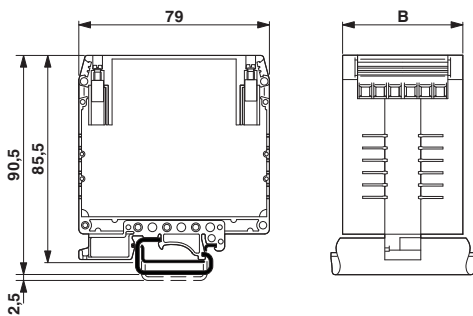

Dimensional drawing

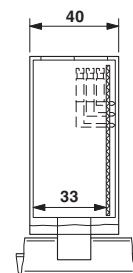

Electronic housing - UEGM 40/1 - 2792112

Dimensional drawing

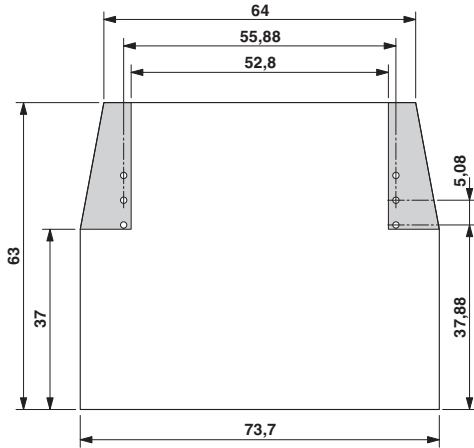

Schematic diagram

