

Distributed I/O device - AXL E EC DI8 DO8 M12 6P - 2701520

Please be informed that the data shown in this PDF Document is generated from our Online Catalog. Please find the complete data in the user's documentation. Our General Terms of Use for Downloads are valid (<http://phoenixcontact.com/download>)



Axioline E-EtherCAT[®] device in a plastic housing with 8 digital inputs and 8 digital outputs, 24 V DC, M12 fast connection technology

Why buy this product

- Connection to EtherCAT[®] network using M12connectors (D-coded)
- Transmission speed of 100 Mbps
- Connection of digital sensors and actuators using M12connectors (A-coded)
- Diagnostic and status indicators
- Short-circuit and overload protection of the sensor supply
- IP65/IP67 degree of protection



Key Commercial Data

Packing unit	1 STK
GTIN	 4 046356 763707

Technical data

Note

Utilization restriction	EMC: class A product, see manufacturer's declaration in the download area
-------------------------	---

Dimensions

Width	60 mm
Height	185 mm
Depth	30.5 mm
Note on dimensions	The height is 212 mm including fixing clips.
Drill hole spacing	198.5 mm

Ambient conditions

Ambient temperature (operation)	-25 °C ... 60 °C
Ambient temperature (storage/transport)	-25 °C ... 85 °C
Permissible humidity (operation)	5 % ... 95 %

Distributed I/O device - AXL E EC DI8 DO8 M12 6P - 2701520

Technical data

Ambient conditions

Permissible humidity (storage/transport)	5 % ... 95 %
Air pressure (operation)	70 kPa ... 106 kPa (up to 3000 m above sea level)
Air pressure (storage/transport)	70 kPa ... 106 kPa (up to 3000 m above sea level)
Degree of protection	IP65/IP67

General

Net weight	480 g
Mounting type	Wall mounting

Interfaces

Fieldbus system	EtherCAT®
Designation	EtherCAT®
Connection method	M12-Schnellanschlusstechnik
Note on connection method	D-coded
Designation connection point	Copper cable
Transmission speed	100 MBit/s (with auto negotiation)
Number of positions	4

System limits of the bus coupler

Designation	EtherCAT®
Equipment type	EtherCAT® slave
System-specific protocols	Mailbox protocols CANopen® over EtherCAT® Mailbox protocols File access over EtherCAT®
Type of addressing	Auto-increment addressing Fixed position addressing Logical addressing
Specification	ETG.1000 V1.02

Power supply for module electronics

Module electronics and sensors	M12 connector (T-coded) Module electronics and sensors (U _S) 4
Connection method	M12 connector (T-coded)
Designation	Module electronics and sensors (U _S)
Number of positions	4
Supply voltage	24 V DC
Nominal supply voltage range	18 V DC ... 31.2 V DC (including all tolerances, including ripple)
Current consumption	max. 12 A
Typical current consumption	190 mA ±15 % (at 24 V DC)
Actuators	M12 connector (T-coded) Actuators (U _A) 4
Connection method	M12 connector (T-coded)
Designation	Actuators (U _A)
Number of positions	4
Supply voltage	24 V DC

Distributed I/O device - AXL E EC DI8 DO8 M12 6P - 2701520

Technical data

Power supply for module electronics

Nominal supply voltage range	18 V DC ... 31.2 V DC (including all tolerances, including ripple)
Current consumption	max. 12 A
Typical current consumption	30 mA ±15 % (at 24 V DC)

Digital inputs

Input name	Digital inputs
Description of the input	EN 61131-2 types 1 and 3
Connection method	M12 connector, double occupancy
	4-wire
Number of inputs	8
Protective circuit	Overload protection, short-circuit protection of sensor supply
Input filter time	< 1000 µs
Input voltage range "0" signal	-30 V DC ... 5 V DC
Input voltage range "1" signal	11 V DC ... 30 V DC
Nominal input current at U _{IN}	typ. 3 mA

Digital outputs

Output name	Digital outputs
Connection method	M12 connector, double occupancy
	3-conductor
Number of outputs	8
Protective circuit	Overload protection, short-circuit protection of outputs Electronic
Output voltage	24 V DC
Nominal output voltage	24 V DC (from voltage U _A)
Maximum output current per channel	500 mA
Nominal load, inductive	12 VA (1.2 H; 48 Ω; with nominal voltage)
Nominal load, ohmic	12 W (48 Ω; with nominal voltage)

Standards and Regulations

Conformity with EMC directives	Noise immunity test in accordance with EN 61000-6-2 Electrostatic discharge (ESD) EN 61000-4-2/IEC 61000-4-2 Criterion B, 6 kV contact discharge, 8 kV air discharge
	Noise immunity test in accordance with EN 61000-6-2 Electromagnetic fields EN 61000-4-3/IEC 61000-4-3 Criterion A; Field intensity: 10 V/m
	Noise immunity test in accordance with EN 61000-6-2 Fast transients (burst) EN 61000-4-4/IEC 61000-4-4 Criterion B, 2 kV
	Noise immunity test in accordance with EN 61000-6-2 Transient overvoltage (surge) EN 61000-4-5/IEC 61000-4-5 Criterion B, DC supply lines: ±0.5 kV/±0.5 kV (symmetrical/asymmetrical)
	Noise immunity test in accordance with EN 61000-6-2 Conducted interference EN 61000-4-6/IEC 61000-4-6 Criterion A; Test voltage 10 V
	Noise emission test as per EN 61000-6-4 Radio interference properties EN 55022 Class A
Test section	24 V supply (communications power and sensor supply, digital inputs)/ bus connection (Ethernet 1) 500 V AC 50 Hz 1 min.

Distributed I/O device - AXL E EC DI8 DO8 M12 6P - 2701520

Technical data

Standards and Regulations

	24 V supply (communications power and sensor supply, digital inputs)/ bus connection (Ethernet 2) 500 V AC 50 Hz 1 min.
	24 V supply (communications power and sensor supply, digital inputs)/ FE 500 V AC 50 Hz 1 min.
	Bus connection (Ethernet 1)/FE 500 V AC 50 Hz 1 min.
	Bus connection (Ethernet 2)/FE 500 V AC 50 Hz 1 min.
	Bus connection (Ethernet 1)/bus connection (Ethernet 2) 500 V AC 50 Hz 1 min.
	24 V supply (actuator supply, digital outputs)/24 V supply (communications power and sensor supply, digital inputs) 500 V AC 50 Hz 1 min.
	24 V supply (actuator supply, digital outputs)/bus connection (Ethernet 1) 500 V AC 50 Hz 1 min.
	24 V supply (actuator supply, digital outputs)/bus connection (Ethernet 2) 500 V AC 50 Hz 1 min.
	24 V supply (actuator supply, digital outputs)/FE 500 V AC 50 Hz 1 min.
Mechanical tests	Vibration resistance in acc. with EN 60068-2-6/IEC 60068-2-6 5g
	Shock in acc. with EN 60068-2-27/IEC 60068-2-27 30g, 11 ms period, half-sine shock pulse
	Continuous shock according to EN 60068-2-27/IEC 60068-2-27 10g
Protection class	III, IEC 61140, EN 61140, VDE 0140-1

Classifications

eCl@ss

eCl@ss 4.0	27240404
eCl@ss 4.1	27240404
eCl@ss 5.0	27242204
eCl@ss 5.1	27242604
eCl@ss 6.0	27242604
eCl@ss 7.0	27242604
eCl@ss 8.0	27242604
eCl@ss 9.0	27242604

ETIM

ETIM 2.0	EC001433
ETIM 3.0	EC001599
ETIM 4.0	EC001599
ETIM 5.0	EC001599

UNSPSC

UNSPSC 6.01	43172015
UNSPSC 7.0901	43201404
UNSPSC 11	39121311

Distributed I/O device - AXL E EC DI8 DO8 M12 6P - 2701520

Classifications

UNSPSC

UNSPSC 12.01	39121311
UNSPSC 13.2	39121311

Approvals

Approvals

Approvals

UL Listed / cUL Listed / EtherCAT® / EtherCAT / cULus Listed

Ex Approvals

UL Listed / cUL Listed / cULus Listed

Approvals submitted

Approval details

UL Listed

cUL Listed

EtherCAT®

EtherCAT

cULus Listed

Drawings

Distributed I/O device - AXL E EC DI8 DO8 M12 6P - 2701520

Connection diagram

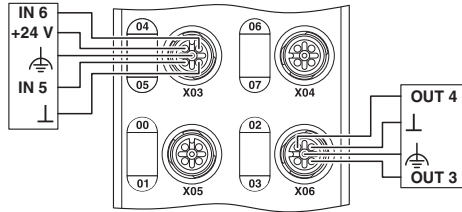

Dimensional drawing

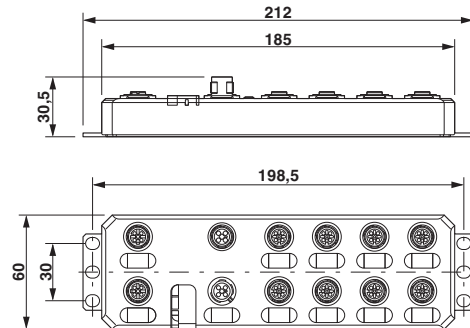

Phoenix Contact 2016 © - all rights reserved
<http://www.phoenixcontact.com>

PHOENIX CONTACT GmbH & Co. KG
Flachsmarktstr. 8
32825 Blomberg
Germany
Tel. +49 5235 300
Fax +49 5235 3 41200
<http://www.phoenixcontact.com>