

Safety relays - PSR-SPP- 24DC/ESD/5X1/1X2/300 - 2981431

Please be informed that the data shown in this PDF Document is generated from our Online Catalog. Please find the complete data in the user's documentation. Our General Terms of Use for Downloads are valid (<http://phoenixcontact.com/download>)



Safety relay for emergency stop and safety door monitoring up to SIL 3 or Cat. 4, PL e (EN ISO 13849), one- or two-channel operation, automatic or manual activation, 3 N/O contacts, 1 N/C contact, 2 N/O contacts with dropout delay of 0.2 s to 300 s, plug-in spring-cage terminal block

The illustration shows the versions with screw connection

Why buy this product

- Maximum of 3 undelayed and 2 dropout delay contacts
- Manually monitored and automatic activation
- Up to Cat. 3/4 and PL d/e according to ISO 13849-1, SILCL 3 according to IEC 62061, SIL 3 according to IEC 61508
- For emergency stop and safety door monitoring, plus evaluation of light grids
- Protective labels to prevent manipulation of the set time (PSR-ESD-300) or electronic protection against manipulation (PSR-ESD-30)
- Single and two-channel control
- Adjustable delay time of 0.2 s ... 300 s (24 increments)



Key Commercial Data

Packing unit	1 STK
GTIN	 4 017918 975234

Technical data

Note

Utilization restriction	EMC: class A product, see manufacturer's declaration in the download area
-------------------------	---

Dimensions

Width	45 mm
Height	112 mm
Depth	114.5 mm

Ambient conditions

Safety relays - PSR-SPP- 24DC/ESD/5X1/1X2/300 - 2981431

Technical data

Ambient conditions

Ambient temperature (operation)	-20 °C ... 55 °C (observe derating)
Ambient temperature (storage/transport)	-40 °C ... 70 °C
Max. permissible relative humidity (operation)	75 % (on average, 85% infrequently, non-condensing)
Max. permissible humidity (storage/transport)	75 % (on average, 85% infrequently, non-condensing)
Shock	15g
Vibration (operation)	10 Hz ...150 Hz, 2g
Maximum altitude	≤ 2000 m (Above sea level)

Input data

Rated control circuit supply voltage U_s	24 V DC -15 % / +10 %
Power consumption at U_s	typ. 3.72 W
Rated control supply current I_s	typ. 155 mA
Typical inrush current	200 mA (at U_s)
Current consumption	< 40 mA (with U_s/I_x to S10)
	< 50 mA (with U_s/I_x to S12)
	> -40 mA (with U_s/I_x to S22)
	0 mA (with U_s/I_x to S34)
	< 5 mA (with U_s/I_x to S35)
Voltage at input/start and feedback circuit	24 V DC -15 % / +10 %
Typical response time	< 600 ms (automatic start)
	< 70 ms (manual start)
Typical pick-up time	< 600 ms (when controlled via A1)
Typical release time	< 20 ms (when controlled via S11/S12 and S21/S22)
	< 20 ms (when controlled via A1)
Concurrence input 1/2	∞
Recovery time	< 1 s
Status display	4 x green LEDs
Maximum switching frequency	0.5 Hz
Max. permissible overall conductor resistance	approx. 22 Ω (Input and start circuits at U_s)
Filter time	1 ms (at A1 in the event of voltage dips at U_s)
	max. 1.5 ms (at S10, S12; test pulse width)
	7.5 ms (at S10, S12; test pulse rate)
	Test pulse rate = 5 x Test pulse width

Output data

Contact type	3 enabling current paths undelayed
	2 enabling current paths delayed
	1 signaling current path undelayed
Contact material	AgSnO ₂
Minimum switching voltage	5 V AC/DC
Maximum switching voltage	250 V AC/DC (Observe the load curve)

Safety relays - PSR-SPP- 24DC/ESD/5X1/1X2/300 - 2981431

Technical data

Output data

Limiting continuous current	6 A (N/O contact, pay attention to the derating)
	6 A (N/C contact)
Inrush current, minimum	10 mA
Maximum inrush current	20 A (Δt # 100 ms, undelayed contacts)
	8 A (delayed contacts)
Sq. Total current	55 A ² (observe derating)
Interrupting rating (ohmic load) max.	144 W (24 V DC, $\tau = 0$ ms)
	288 W (48 V DC, $\tau = 0$ ms)
	110 W (110 V DC, $\tau = 0$ ms, delayed contacts: 77 W)
	88 W (220 V DC, $\tau = 0$ ms)
	1500 VA (250 V AC, $\tau = 0$ ms, delayed contacts: 2000 VA)
Maximum interrupting rating (inductive load)	42 W (24 V DC, $\tau = 40$ ms, delayed contacts: 48 W)
	42 W (48 V DC, $\tau = 40$ ms, delayed contacts: 40 W)
	42 W (110 V DC, $\tau = 40$ ms, delayed contacts: 35 W)
	42 W (220 V DC, $\tau = 40$ ms, delayed contacts: 33 W)
Switching capacity min.	50 mW
Output fuse	10 A gL/gG (N/O contact)
	6 A gL/gG (N/C contact)

General

Relay type	Electromechanical relay with forcibly guided contacts in accordance with EN 50205
Mechanical service life	10 x 10 ⁶ cycles
Net weight	420.03 g
Mounting type	DIN rail mounting
Degree of protection	IP54
	IP20
Min. degree of protection of inst. location	IP54
Mounting position	any
Control	one and two channel
Housing material	PBT

Connection data

Connection method	Spring-cage connection
pluggable	Yes
Conductor cross section solid min.	0.2 mm ²
Conductor cross section solid max.	1.5 mm ²
Conductor cross section flexible min.	0.2 mm ²
Conductor cross section flexible max.	1.5 mm ²
Conductor cross section AWG min.	24
Conductor cross section AWG max.	16
Stripping length	8 mm

Safety relays - PSR-SPP- 24DC/ESD/5X1/1X2/300 - 2981431

Technical data

Safety-related characteristic data

Stop category	0
	1
Designation	IEC 61508 - High demand
Safety Integrity Level (SIL)	3 (for delayed contacts SIL 2)
Designation	IEC 61508 - Low demand
Safety Integrity Level (SIL)	3 (for delayed contacts SIL 2)
Designation	EN ISO 13849
Performance level (PL)	e (for delayed contacts PL d)
Category	4 (undelayed contacts)
Designation	EN 62061
Safety Integrity Level Claim Limit (SIL CL)	3 (for delayed contacts SILCL 2)

Standards and Regulations

Shock	15g
Designation	Air clearances and creepage distances between the power circuits
Standards/regulations	DIN EN 50178/VDE 0160
Rated insulation voltage	250 V AC
Rated surge voltage/insulation	Basic insulation 4 kV: between all current paths and housing Safe isolation, reinforced insulation 6 kV: between 13/14, 23/24, 33/34, and the remaining current paths between 13/14, 23/24, 33/34 among one another
Degree of pollution	2
Overvoltage category	III
Vibration (operation)	10 Hz ... 150 Hz, 2g
Conformance	CE-compliant

Classifications

eCl@ss

eCl@ss 4.0	27371102
eCl@ss 4.1	27371102
eCl@ss 5.0	27371901
eCl@ss 5.1	27371901
eCl@ss 6.0	27371819
eCl@ss 7.0	27371819
eCl@ss 8.0	27371819

ETIM

ETIM 2.0	EC001449
ETIM 3.0	EC001449
ETIM 4.0	EC001449
ETIM 5.0	EC001449

Safety relays - PSR-SPP- 24DC/ESD/5X1/1X2/300 - 2981431

Classifications

UNSPSC

UNSPSC 6.01	30211901
UNSPSC 7.0901	39121501
UNSPSC 11	39121501
UNSPSC 12.01	39121501
UNSPSC 13.2	39121501

Approvals

Approvals

Approvals

UL Listed / cUL Listed / Functional Safety / EAC / EAC / cULus Listed

Ex Approvals

Approvals submitted

Approval details

UL Listed

cUL Listed

Functional Safety

EAC

EAC

cULus Listed

Drawings

Safety relays - PSR-SPP- 24DC/ESD/5X1/1X2/300 - 2981431

Circuit diagram

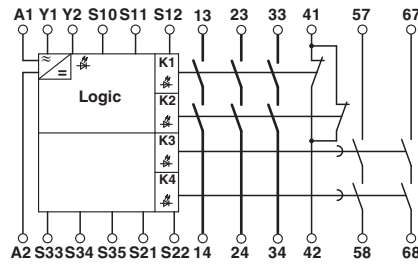

Circuit diagram

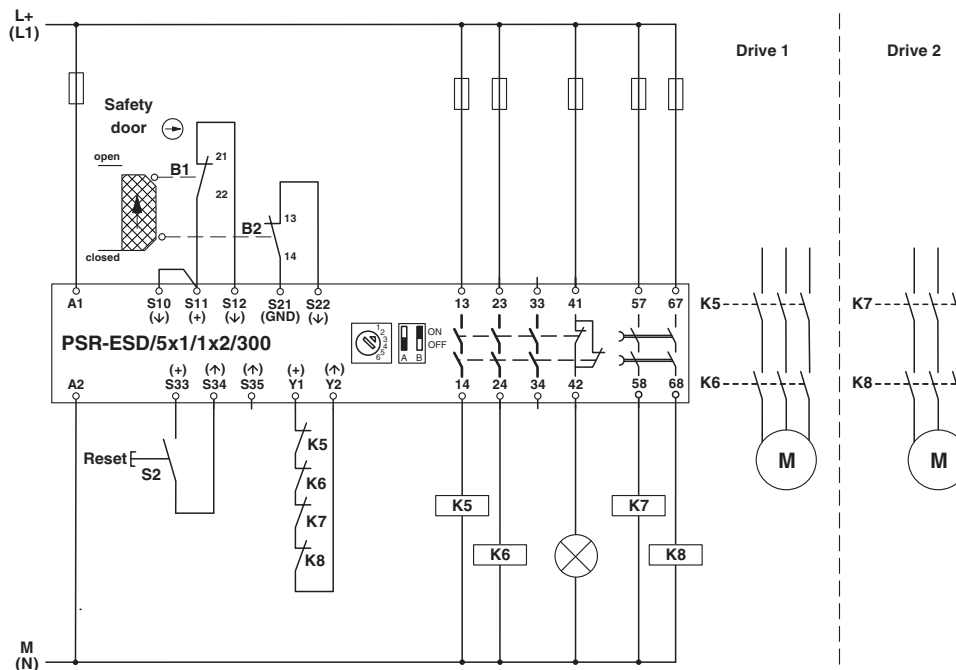

Two-channel safety door monitoring

Phoenix Contact 2016 © - all rights reserved
<http://www.phoenixcontact.com>

PHOENIX CONTACT GmbH & Co. KG
 Flachsmarktstr. 8
 32825 Blomberg
 Germany
 Tel. +49 5235 300
 Fax +49 5235 3 41200
<http://www.phoenixcontact.com>