

# CUC-V14-F1ZNI-EM/R4B8 - Panel-mount frame



1413962

<https://www.phoenixcontact.com/nl/products/1413962>

Please be informed that the data shown in this PDF document is generated from our online catalog. Please find the complete data in the user documentation. Our general terms of use for downloads are valid.



RJ45 panel mounting frame, IP67, for push-pull interlocking, metal, for rectangular mounting cutout, with seal and mounting screws, incl. RJ45 coupling module

## Commercial data

Item number	1413962
Packing unit	1 pc
Minimum order quantity	1 pc
Sales key	ABNODB
Product key	ABNODB
GTIN	4055626082141
Weight per piece (including packing)	43,3 g
Weight per piece (excluding packing)	38,562 g
Customs tariff number	85366990
Country of origin	TW

## Technical data

### Notes

General	This product corresponds to the PROFINET Cabling and Interconnection Technology Guideline for PROFINET regulations, version 2.00, order no: 2.252, Chapter 8.2 Connectors for Outside Environment (Balanced cabling) and chapter 13 Application specific Cabling and Interconnection Technology (AIDA)
---------	--

### Product properties

Type	RJ45
Number of positions	8
Connection profile	RJ45
Number of slots	2

### Insulation characteristics

Degree of pollution	2
---------------------	---

### Electrical properties

Rated voltage (III/3)	72 V (DC)
Rated surge voltage	1 kV
Operating voltage	72 V (DC)
Frequency range	500 MHz
Insulation resistance	> 500 MΩ
Transmission medium	Copper
Transmission speed	10 Gbps

### Dimensions

Width	22.2 mm
Height	42 mm
Length	46.2 mm

### Material specifications

Material	Metal
Flammability rating according to UL 94	V0
Seal material	NBR
	NBR
Housing material	Metal
Housing surface material	nickel-plated
Material, protective cover	PC

### Cable/line

Shielded	yes
----------	-----

### Mechanical properties

# CUC-V14-F1ZNI-EM/R4B8 - Panel-mount frame



1413962

<https://www.phoenixcontact.com/nl/products/1413962>

## Mechanical data

Insertion/withdrawal cycles	≥ 750
-----------------------------	-------

## Environmental and real-life conditions

### Ambient conditions

Degree of protection	IP65/IP67
Ambient temperature (operation)	-40 °C ... 68 °C
Ambient temperature (storage/transport)	-40 °C ... 70 °C
Ambient temperature (assembly)	-10 °C ... 60 °C

# CUC-V14-F1ZNI-EM/R4B8 - Panel-mount frame

1413962

<https://www.phoenixcontact.com/nl/products/1413962>



## Drawings

Drilling plan/solder pad geometry

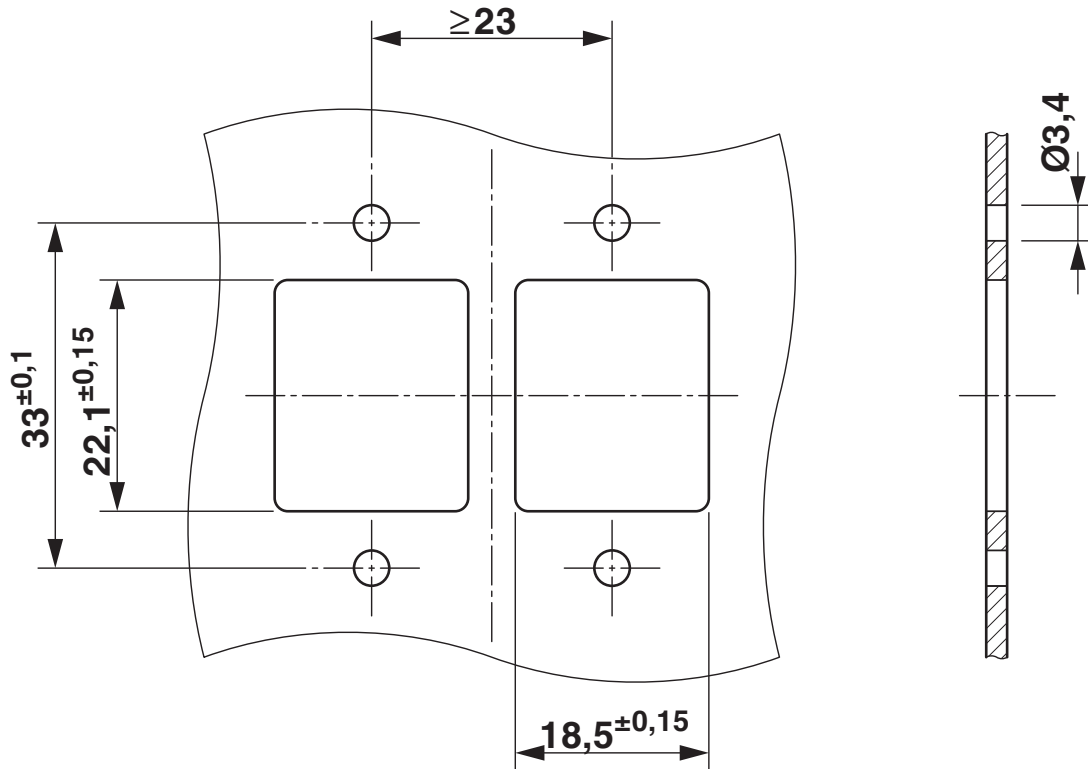

# CUC-V14-F1ZNI-EM/R4B8 - Panel-mount frame



1413962

<https://www.phoenixcontact.com/nl/products/1413962>

## Approvals

To download certificates, visit the product detail page: <https://www.phoenixcontact.com/nl/products/1413962>

 <b>cULus Recognized</b> Approval ID: E335024-20160727				
	Nominal voltage $U_N$	Nominal current $I_N$	Cross section AWG	Cross section $\text{mm}^2$
keine				
	56.5 V	0.175 A	-	-

# CUC-V14-F1ZNI-EM/R4B8 - Panel-mount frame



1413962

<https://www.phoenixcontact.com/nl/products/1413962>

## Classifications

### ECLASS

ECLASS-13.0	27440210
ECLASS-15.0	27440210

### ETIM

ETIM 10.0	EC002310
-----------	----------

### UNSPSC

UNSPSC 21.0	39121400
-------------	----------

# CUC-V14-F1ZNI-EM/R4B8 - Panel-mount frame



1413962

<https://www.phoenixcontact.com/nl/products/1413962>

## Environmental product compliance

### EU RoHS

Fulfills EU RoHS substance requirements	Yes, No exemptions
---	--------------------

### China RoHS

Environment friendly use period (EFUP)	EFUP-E
	No hazardous substances above the limits

### EU REACH SVHC

REACH candidate substance (CAS No.)	No substance above 0.1 wt%
-------------------------------------	----------------------------

Phoenix Contact 2026 © - all rights reserved  
<https://www.phoenixcontact.com>

PHOENIX CONTACT B.V.  
Hengelder 56 6902 PA Zevenaar  
Postbus 246 6900 AE Zevenaar  
(0316) 59 17 20  
[sales@phoenixcontact.nl](mailto:sales@phoenixcontact.nl)