

MC 1,5/10-LWL 2,3-3,81 - Fiber optic

1841190

<https://www.phoenixcontact.com/nl/products/1841190>

Please be informed that the data shown in this PDF document is generated from our online catalog. Please find the complete data in the user documentation. Our general terms of use for downloads are valid.

MINI COMBICON fiber optics, 3.81 mm pitch, 10-pos., separable for other numbers of positions (minimum: 2-pos.), inserts into the back of the MC header, color: transparent, dimension a: 2.3 mm



Your advantages

- Bending of the light coming from low-profile SMD LEDs by 90°, making it visible from the front
- 10-pos., can be separated for other numbers of positions
- Minimum size 2-pos.

Commercial data

Item number	1841190
Packing unit	50 pc
Minimum order quantity	50 pc
Sales key	AAHZEB
Product key	AAHZEB
GTIN	4017918111830
Weight per piece (including packing)	3,536 g
Weight per piece (excluding packing)	3,538 g
Customs tariff number	85389099
Country of origin	DE

MC 1,5/10-LWL 2,3-3,81 - Fiber optic

1841190

<https://www.phoenixcontact.com/nl/products/1841190>

Technical data

Product properties

Product family	MC 1,5/..-LWL
Number of positions	10
Pitch	3.81 mm

Dimensions

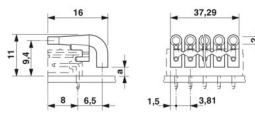
Dimensional drawing	
Pitch	3.81 mm

Material specifications

Color (Light guide)	transparent
Flammability rating according to UL 94	HB

MC 1,5/10-LWL 2,3-3,81 - Fiber optic

1841190

<https://www.phoenixcontact.com/nl/products/1841190>



Drawings

Dimensional drawing

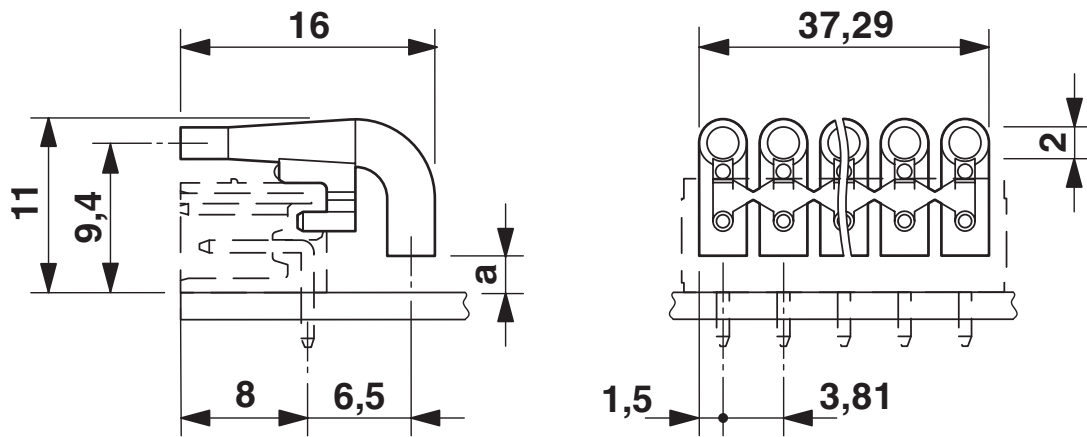

MC 1,5/10-LWL 2,3-3,81 - Fiber optic



1841190

<https://www.phoenixcontact.com/nl/products/1841190>

Classifications

ECLASS

ECLASS-13.0	27460404
ECLASS-15.0	27460404

ETIM

ETIM 10.0	EC002943
-----------	----------

UNSPSC

UNSPSC 21.0	39121400
-------------	----------

MC 1,5/10-LWL 2,3-3,81 - Fiber optic



1841190

<https://www.phoenixcontact.com/nl/products/1841190>

Environmental product compliance

EU RoHS

Fulfills EU RoHS substance requirements	Yes, No exemptions
---	--------------------

China RoHS

Environment friendly use period (EFUP)	EFUP-E
	No hazardous substances above the limits

EU REACH SVHC

REACH candidate substance (CAS No.)	No substance above 0.1 wt%
-------------------------------------	----------------------------

Phoenix Contact 2026 © - all rights reserved
<https://www.phoenixcontact.com>

PHOENIX CONTACT B.V.
Hengelder 56 6902 PA Zevenaar
Postbus 246 6900 AE Zevenaar
(0316) 59 17 20
sales@phoenixcontact.nl