

**DESIGNED AND DIMENSIONED IN MILLIMETERS[INCHES]
ALL DIMENSIONS REFERENCE EXCEPT AS SHOWN**

ADM6-XXX-XX.X-XXX-4-X-X-XR

No OF POSITIONS

-10, -20, -30, -40, -50, -60,
**-70, **-80, **-90, **-100
(PER ROW)

PACKAGING

(SEE NOTES 1, 3 & 4)
-TR: TAPE & REEL
-FR: FULL REEL QTY TAPE & REEL

OPTION

BLANK: NO ALIGNMENT PIN
-A: ALIGNMENT PIN
(SEE SHT 3, FIG 3)

TERMINATION

**-0: COLUMN (SEE NOTE 6)
*Ø-1: BALL (63.0% TIN/37% LEAD)
-2: BALL (96.5% TIN/3.0% SILVER
0.5% COPPER)

LEAD STYLE

-01.5: 1.5MM
-03.5: 3.5MM
-06.5: 6.5MM
-08.5: 08.5MM

PLATING SPECIFICATION

-L: 10µ" SELECTIVE GOLD
IN CONTACT AREA,
MATTE TIN ON TAIL
-S: 30µ" SELECTIVE GOLD
IN CONTACT AREA,
MATTE TIN ON TAIL
*-STL: 30µ" SELECTIVE GOLD
IN CONTACT AREA,
TIN/LEAD ON TAIL

4 ROW

(Ø = ONLY AVAILABLE WITH -STL PLATING)
(* = NOT RELEASED FOR -03.5, 06.5, 08.5 LEAD STYLES)
(** = NOT RELEASED FOR -08.5 LEAD STYLES)

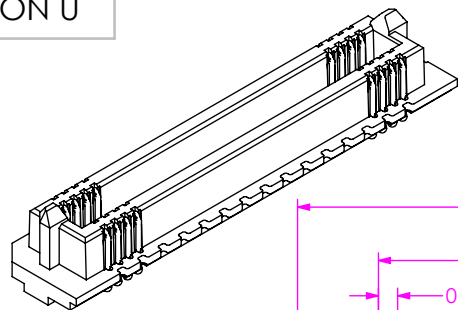

DO NOT
SCALE FROM
THIS PRINT

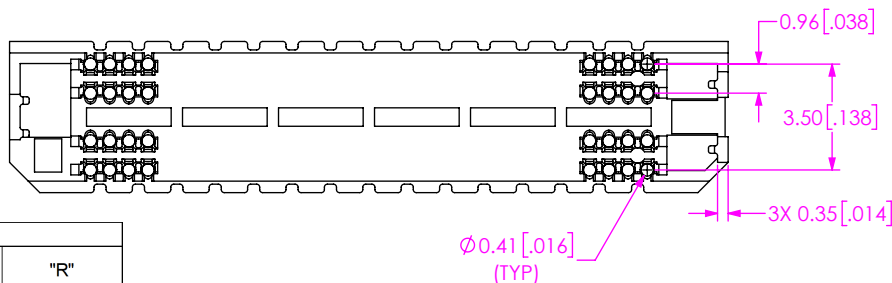
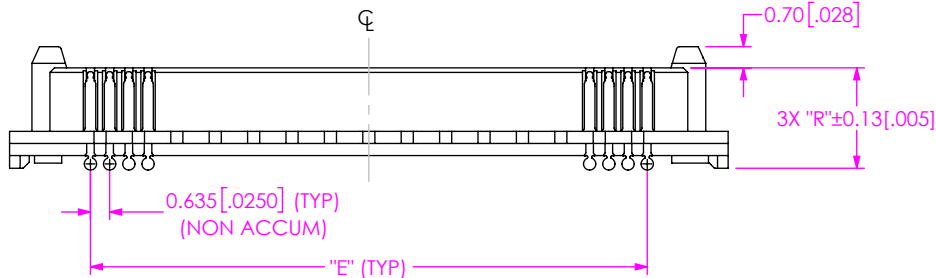
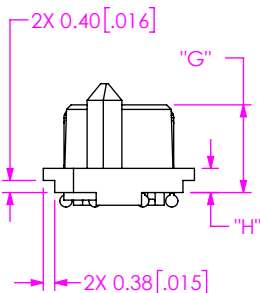
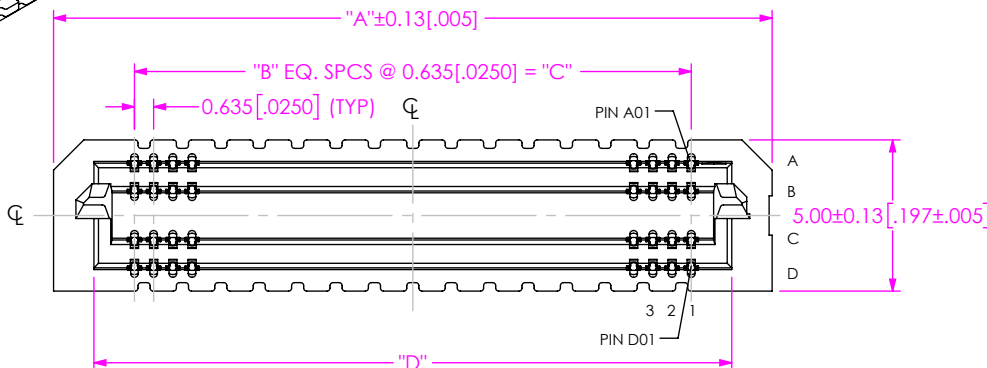

TABLE 1
STACK HEIGHT

ADM6 LEAD STYLE	ADM6 LEAD STYLE			
	-01.5	-03.5	-06.5	-08.5
-03.5	5.00 [0.197]	7.00 [0.276]	10.00 [0.394]	12.00 [0.472]
-07.5	9.00 [0.354]	11.00 [0.433]	14.00 [0.551]	16.00 [0.630]

TABLE 2

No. OF POS. PER ROW	"A"	"B"	"C"	"D"	"E"
-10	11.07 [0.4356]	9	5.715 [0.2250]	8.395 [0.3305]	5.72 [0.2250]
-20	17.42 [0.6856]	19	12.065 [0.4750]	14.745 [0.5805]	12.07 [0.4750]
-30	23.77 [0.9356]	29	18.415 [0.7250]	21.095 [0.8305]	18.42 [0.7250]
-40	30.12 [1.1856]	39	24.765 [0.9750]	27.445 [1.0805]	24.77 [0.9750]
-50	36.47 [1.4356]	49	31.115 [1.2250]	33.795 [1.3305]	31.12 [1.2250]
-60	42.82 [1.6856]	59	37.465 [1.4750]	40.145 [1.5805]	37.47 [1.4750]
-70	49.17 [1.9356]	69	43.815 [1.7250]	46.495 [1.8305]	43.82 [1.7250]
-80	55.52 [2.1856]	79	50.165 [1.9750]	52.845 [2.0805]	50.17 [1.9750]
-90	61.87 [2.4356]	89	56.515 [2.2250]	59.195 [2.3305]	56.52 [2.2250]
-100	68.22 [2.6856]	99	62.865 [2.4750]	65.545 [2.5805]	62.87 [2.4750]

TABLE 3

LEAD STYLE	"G"	"H"	"R"
-01.5	2.900 [0.1142]	0.800 [0.0315]	3.32 [0.131]
-03.5	4.900 [0.1929]	2.800 [0.1102]	5.32 [0.209]
-06.5	7.900 [0.3110]	5.800 [0.2283]	8.32 [0.328]
-08.5	9.900 [0.3898]	7.800 [0.3071]	10.32 [0.406]

FIG 1
ADM6-30-01.5-XXX-4-X-XR SHOWN
(SOME CENTER FEATURES REMOVED FOR CLARITY)

1. TAPE & REEL IS STANDARD PACKAGING.
2. NOTE DELETED.
3. ORDERS WILL BE PACKAGED ACCORDING TO THE SAMTEC PACKAGING EFFICIENCY STANDARDS (SPES) FOUND ON WWW.SAMTEC.COM
4. ATTACH LABEL-4X2 TO EACH REEL.
5. K-DOT PROVIDED AS STANDARD.
6. -L AND -S PLATED PARTS WILL HAVE MATTE TIN ON THE TAIL. -STL PLATED PARTS WILL HAVE TIN/LEAD ON THE TAIL. PARTS ARE SOLDERED WITH OPTIMIZED SOLDER PASTE VOLUME IN PLACE OF AN ATTACHED SOLDER BALL. FOR MORE INFORMATION, CONTACT SAMTEC'S INTERCONNECT PROCESSING GROUP (IPG@SAMTEC.COM).

PROPRIETARY NOTE
THIS DOCUMENT CONTAINS CONFIDENTIAL AND PROPRIETARY INFORMATION AND ALL DESIGN, MANUFACTURING, REPRODUCTION, USE, PATENT RIGHTS AND SALES RIGHTS ARE EXPRESSLY RESERVED BY SAMTEC, INC. THIS DOCUMENT SHALL NOT BE DISCLOSED, IN WHOLE OR PART, TO ANY UNAUTHORIZED PERSON OR ENTITY NOR REPRODUCED, TRANSFERRED OR INCORPORATED IN ANY OTHER PROJECT IN ANY MANNER WITHOUT THE EXPRESS WRITTEN CONSENT OF SAMTEC, INC.

DO NOT SCALE DRAWING
SHEET SCALE: 4:1

MATERIAL:
INSULATOR: LCP, COLOR BLACK
CONTACT: COPPER ALLOY

samtec
520 PARK EAST BLVD, NEW ALBANY, IN 47150
PHONE: 812-944-6733 FAX: 812-948-5047
e-Mail info@SAMTEC.com code 55322

DESCRIPTION:
ADM6 ASSEMBLY

DWG. NO.
ADM6-XXX-XX.X-XXX-4-X-X-XR

BY: J RUZZI 6/14/2016 SHEET 1 OF 3

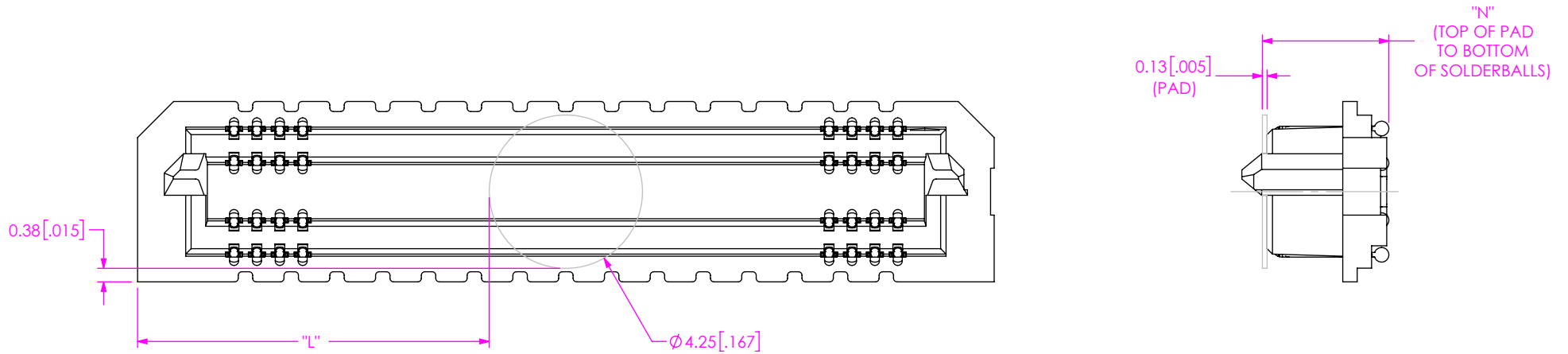

FIG 2
 POLYIMIDE PAD
 ADM6-30-1.5-XXX-4-X-XR SHOWN
 (SAME AS FIG1, EXCEPT AS SHOWN)
 (SOME CENTER FEATURES REMOVED FOR CLARITY)

-No. OF POS PER ROW	"L"
-10	3.41 [0.134]
-20	6.58 [0.259]
-30	9.76 [0.384]
-40	12.93 [0.509]
-50	16.11 [0.634]
-60	19.28 [0.759]
-70	22.46 [0.884]
-80	25.63 [1.009]
-90	28.81 [1.134]
-100	31.98 [1.259]

LEAD STYLE	"N"
-01.5	3.53 [0.139]
-03.5	5.53 [0.218]
-06.5	8.53 [0.336]
-08.5	10.53 [0.415]

PROPRIETARY NOTE
 THIS DOCUMENT CONTAINS CONFIDENTIAL AND PROPRIETARY INFORMATION AND ALL DESIGN, MANUFACTURING, REPRODUCTION, USE, PATENT RIGHTS AND SALES RIGHTS ARE EXPRESSLY RESERVED BY SAMTEC, INC. THIS DOCUMENT SHALL NOT BE DISCLOSED, IN WHOLE OR PART, TO ANY UNAUTHORIZED PERSON OR ENTITY NOR REPRODUCED, TRANSFERRED OR INCORPORATED IN ANY OTHER PROJECT IN ANY MANNER WITHOUT THE EXPRESS WRITTEN CONSENT OF SAMTEC, INC.



520 PARK EAST BLVD, NEW ALBANY, IN 47150
 PHONE: 812-944-6733 FAX: 812-948-5047
 e-Mail info@SAMTEC.com code 55322

DO NOT SCALE DRAWING
 SHEET SCALE: 6:1

DESCRIPTION:	ADM6 ASSEMBLY
DWG. NO.	ADM6-XXX-XX.X-XXX-4-X-X-XR
BY: J RUZZI	6/14/2016
	SHEET 2 OF 3

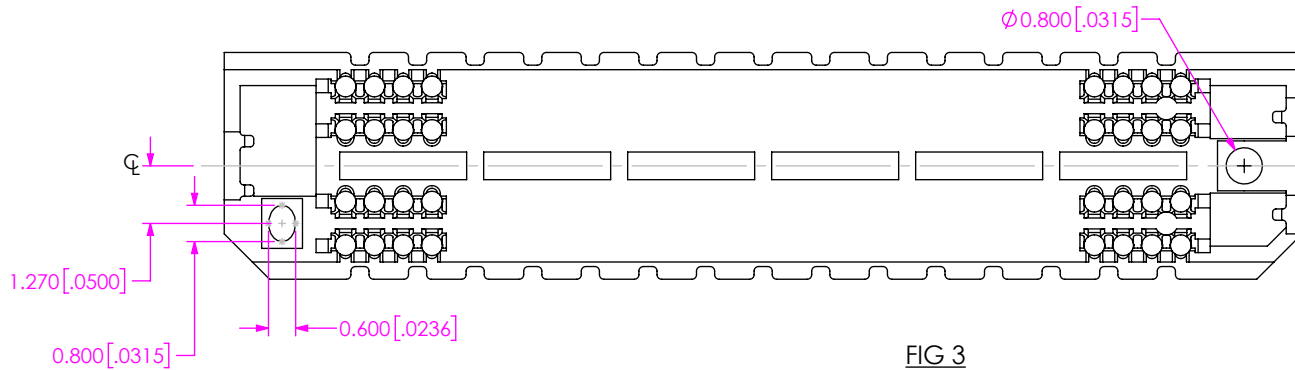
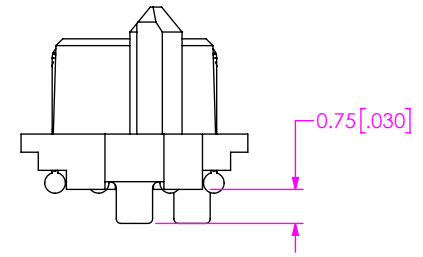
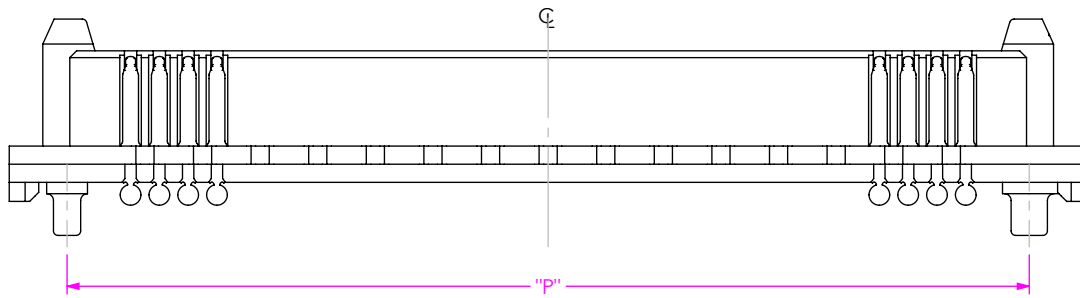

TABLE 6

No OF POS PER ROW	"P"
-10	8.52 [0.335]
-20	14.87 [0.585]
-30	21.22 [0.835]
-40	27.57 [1.085]
-50	33.92 [1.335]
-60	40.27 [1.585]
-70	46.62 [1.835]
-80	52.97 [2.085]
-90	59.32 [2.335]
-100	65.67 [2.585]

FIG 3
 -A: ALIGNMENT PIN
 ADM6-30-01.5-XXX-4-X-A-XR SHOWN
 (SAME AS FIG 1, EXCEPT AS SHOWN)
 (SOME CENTER FEATURES REMOVED FOR CLARITY)

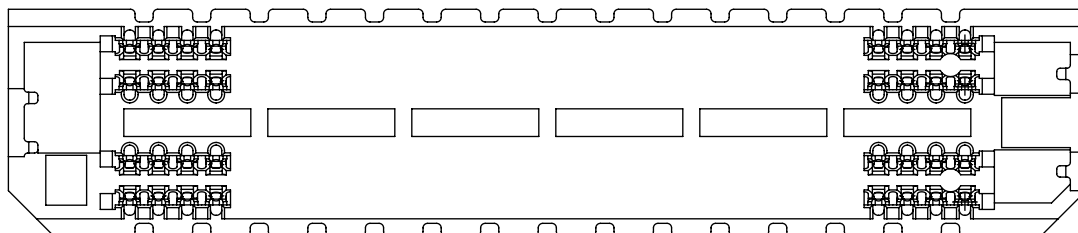
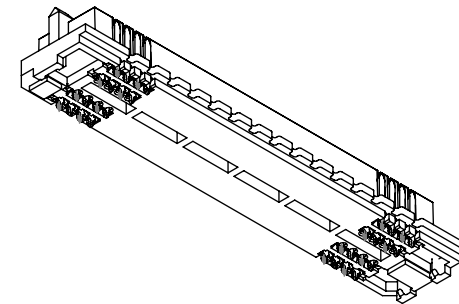
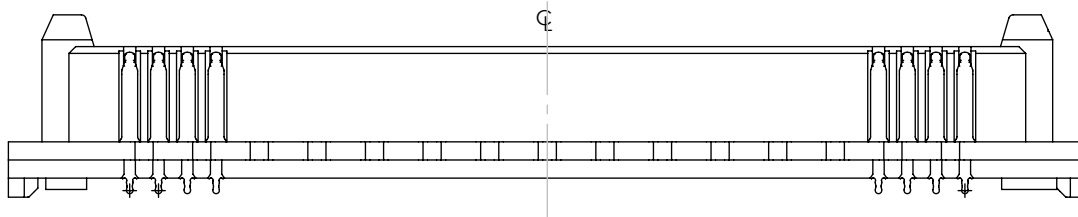

FIG 4
 ADM6-30-01.5-XXX-4-0-XR SHOWN
 (SAME AS FIG 1, EXCEPT AS SHOWN)
 (NO SOLDER BALL OPTION)
 (SOME CENTER FEATURES REMOVED FOR CLARITY)

PROPRIETARY NOTE
 THIS DOCUMENT CONTAINS CONFIDENTIAL AND PROPRIETARY INFORMATION AND ALL DESIGN, MANUFACTURING, REPRODUCTION, USE, PATENT RIGHTS AND SALES RIGHTS ARE EXPRESSLY RESERVED BY SAMTEC, INC. THIS DOCUMENT SHALL NOT BE DISCLOSED, IN WHOLE OR PART, TO ANY UNAUTHORIZED PERSON OR ENTITY NOR REPRODUCED, TRANSFERRED OR INCORPORATED IN ANY OTHER PROJECT IN ANY MANNER WITHOUT THE EXPRESS WRITTEN CONSENT OF SAMTEC, INC.



520 PARK EAST BLVD, NEW ALBANY, IN 47150
 PHONE: 812-944-6733 FAX: 812-948-5047
 e-Mail info@SAMTEC.com code 55322

DO NOT SCALE DRAWING

SHEET SCALE: 6:1

DESCRIPTION:
 ADM6 ASSEMBLY

DWG. NO.
ADM6-XXX-XX.X-XXX-4-X-X-XR

BY: J RUZZI 6/14/2016 SHEET 3 OF 3