

DC Push Tubular Solenoid



Model TP6x12

Features:

- High performance construction
- Available return spring kit
- DC applications only
- See T6x12 for pull applications
- UL recognized



Electrical:

- Coil Voltages: 6, 12, 24, 48, 110VDC standard
- Coil Termination: 6.5" Wire leads
- 26 AWG (standard)
- Duty Cycle: 100% Continuous, 25% Intermittent, 10% Intermittent, 1% Pulse
- Coil treatment: Tape Wrapped
- Insulation Class: Class A Rating - 105° C (221° F)
- Dielectric Strength: 1500V 60 Hz

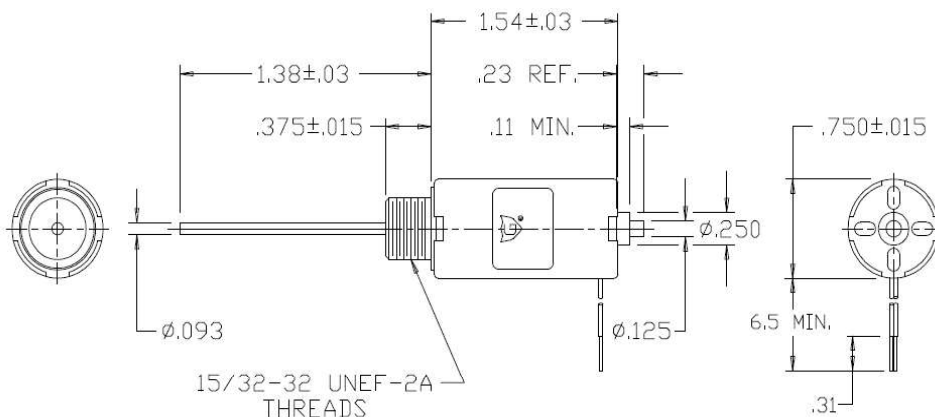

Mechanical:

- Size: 1.54" (L) x .75" (D)
- Plunger Diameter: 0.093"
- Plunger Guide Material: Plastic
- Mounting: Hex Nut
- Weight: Plunger .4 oz, Total 2.3 oz
- Life Expectancy: 1 Million Cycles¹

¹ - Dependent on load conditions

Solenoid shown energized with plunger fully seated in extended position
Supplied with mounting bracket, hex nut and lock washer shipped loose

Standard Part Numbers

Model	Part Number	Duty Cycle	Voltage	Resistance ² (Ω)	Power (W)	Current
TP6x12-C-12	A420-066091-00	Cont.	12VDC	31.7	4.8	379 mA
TP6x12-I-12	A420-066092-00	Inter.	12VDC	12.1	12.5	992 mA
TP6x12-C-24	A420-066093-00	Cont.	24VDC	121	5	198 mA
TP6x12-I-24	A420-066094-00	Inter.	24VDC	60.6	10.1	399 mA

² - Coil resistance tolerance +/- 5%

Contact us for custom voltages or duty cycles

Available Customization:

- Plunger
 - Lead and Connector
 - DC Voltage
 - Duty Cycle
 - Insulation systems up to class H 180° C (356° F)
- * Minimum quantities apply

Stroke (in.)	Typical Push Force Ounces [N] @ 20°C (68°F) (Distance from fully extended position)						HOLDING FORCE Ounces [N]	Power (W)
	0.050	0.125	0.250	0.375	0.500	0.625		
Continuous 100%	13 [3.6]	7 [1.9]	4 [1.1]	2 [0.6]	N/A	N/A	38 [10.6]	5
Intermittent 25%	19 [5.3]	10 [2.8]	7 [1.9]	5 [1.4]	N/A	N/A	43 [12]	11
Intermittent 10% ³	35 [9.7]	23.5 [6.5]	16 [4.4]	12 [3.3]	9.5 [2.6]	4.5 [1.3]	104 [28.9]	37.2
Pulse 1% ³	45 [12.5]	34 [9.5]	25 [7]	18 [5]	13 [3.6]	10 [2.8]	N/A	69.4

Continuous Duty 100% = 100% On Time
Intermittent Duty 25% = 25% On Time (100 Seconds On Max Followed By 300 Seconds Off)
Intermittent Duty 10% = 90% On Time (10 Seconds On Max Followed By 90 Seconds Off)
Pulse Duty 1% = 99% On Time (1 Second On Max Followed By 99 Seconds Off)

³ - Calculated force values to be verified in application

Optional Return Spring Kit

A490-367460-13



GUARDIAN-ELECTRIC.COM

1425 Lake Ave - Woodstock IL 60098 - Phone: 800-762-0369

The information is subject to change without notice. © Guardian Electric

