



# HONEYWELL

## 578X1G48S103SA

*See full Datasheet below...*

**onlinecomponents.com**

THE ONLINE DISTRIBUTOR OF ELECTRONIC COMPONENTS

**BUY NOW**



**MASTER**<sup>TM</sup>  
ELECTRONICS

**BUY NOW**

masterelectronics.com & onlinecomponents.com  
are **authorized** e-commerce distributors  
of electronic components.

ALL NEW Series 578

# Precision Potentiometer/ Position Sensor



The **ALL NEW** Series 578 conductive plastic precision potentiometer puts CLAROSTAT proven variable resistor technology to work in a high performance, cost effective device. With its compact size, rugged construction and advanced versatility, the 578 provides superior control for applications such as joy stick controllers and position sensing devices where frequent manual adjustment is required. This control offers linearity of 1%, rotational life of 5MM shaft revolutions for demanding applications, and comes with several options of terminal configurations. A wide variety of electrical output options and mechanical packages are available to suit specific applications with details available from CLAROSTAT applications engineering.

## FEATURES

- Conductive Plastic Element
- Smooth Feel
- 5MM Shaft Revolutions
- Quiet Electrical Output
- Robust Construction
- Center Tap
- Optional Terminal Configurations

ALL NEW Series 578

# Precision Potentiometer/Position Sensor

## SPECIFICATIONS

### ELECTRICAL

Resistance Range:	100 to 2.5 megohm, linear 500 to 1 megohm, non-linear
Tolerance:	±10% std.
Working Voltage:	400 Vdc
Insulation Resistance (min.):	1000 megohm
Dynamic Noise:	2% max. crv
Independent Linearity:	1%
Power Rating:	.5w at 70°C
Dielectric Strength:	750 Vrms
Electrical Rot.:	310° +0 -3°
Temperature Coefficient:	800 ppm/°C
Effective Rotation:	292° ±2°
Electrical Tap:	Tap Width: 5° to 45° Tap Resistance: 1% of Tot. R

### MECHANICAL

Mechanical Rotation:	320° ±5° (resistance decreases w CW rot from CCW end)
Stop Torque:	40 oz. in. min.
Operating Torque:	1 oz. in. max.
Mounting Torque:	25 in. lb. max.

### OPERATIONAL

Operating Temperature:	Static -55° to +120° C Dynamic -40° to +100°C
Temperature Cycling:	5 cycles, -40° to +100°C
Rotational Life:	5MM shaft revs.
Shock:	100g
Vibration:	10g, 10 to 500Hz

## PHYSICAL DIMENSIONS

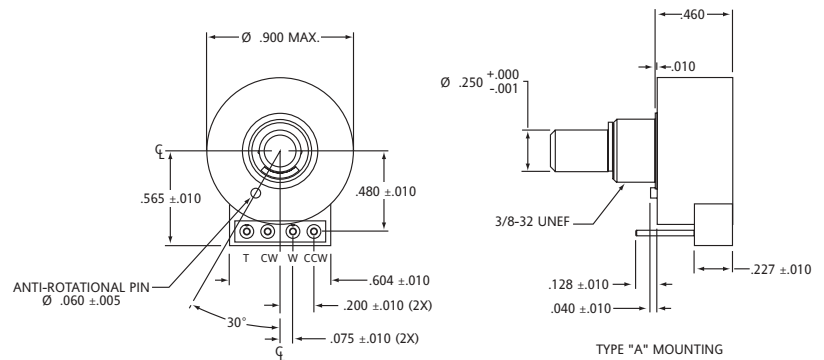

## CONSTRUCTION

Shaft:	Stainless steel
Bushing:	Brass, Nickel plated
Housing:	Molded plastic
Contact Spring:	Monel
Terminals:	PC pins: Brass, Tin plated Wire leads PC board extension
Marking:	Ink stamp on rear
Hardware:	Hex mtg nut Internal tooth lockwasher

## ORDERING INFORMATION

**STANDARD PRODUCT** (identified by significant part number designated by matrix of options below)

Configured OEM selection matrix\*  
578 X 1 G 48 S 103 S P

X = Mechanical X = standard F = center tap	103 = Resistance Value EIA code, first two significant digits, third is number of zeros
1 = Locating Pin 1 = pin at 7:00 0 = no locating pin	S = Resistance Taper S = linear Z = CW audio R = CCW audio
G = Bushing/Shaft G = 3/8D x 3/8 L; 1/4 d shaft B = 3/8D x 3/8L; 1/8 d shaft	A = Terminals
48 = Shaft Length Increments of 64th in. 32 min; 64 max.	A = PC pin type A W = wire lead
S = Shaft End Style S = slot F = flat P = plain round	

\* consult factory for custom OEM configurations